

## PEGASUS F3 N 2S

cast iron gas boiler  
for heating with electronic  
ignition and flame control

ISO 9001 : 2000  
CERTIFIED COMPANY



INSTRUCTIONS FOR USE, INSTALLATION AND MAINTENANCE

## **IMPORTANT**

Your "benchmark" Installation, Commissioning and Service Record Log Book is enclosed in the last pages of this manual. "This record must be completed and left with the end user".

Ferroli is a member of the Benchmark initiative and fully supports the aims of the programme. Benchmark has been introduced to improve the standards of installation and commissioning of central heating systems in the UK and to encourage the regular servicing of all central heating systems to ensure safety and efficiency.

Please see installation and servicing guidelines.



- Carefully read the warnings in this instruction booklet since they provide important information on safe installation, use and maintenance.
- This instruction booklet is an integral part of the product and must be carefully kept by the user for future reference.
- If the unit is sold or transferred to another owner or if it is to be moved, always make sure that the booklet accompanies the boiler so that it can be consulted by the new owner and/or installer.
- Installation and maintenance must be carried out by professionally qualified personnel, according to current regulations and the manufacturer's instructions.
- Incorrect installation or poor maintenance can cause damage or physical injury. The manufacturer declines any responsibility for damage caused by errors in installation and use or by failure to follow the manufacturer's instructions
- Before carrying out any cleaning or maintenance operation, disconnect the device from electrical power supply using the switch and/or the special cutoff devices.
- In case the unit breaks down and/or functions poorly, deactivate it, do not make any attempt to repair it or directly intervene. Contact professionally qualified personnel.
- Any repair/replacement of products must only be carried out by qualified professional personnel using exclusively genuine parts. Failure to comply with the above could affect the safety of the unit.
- Yearly maintenance carried out by qualified personnel is essential for guaranteeing good operation of the unit.
- This unit must only be used for the purpose for which it was designed. Any other use is considered improper and therefore hazardous.
- After removing the packing, check the integrity of the contents.
- Packing materials must not be left within the reach of children as they are potentially hazardous.
- In case of doubt do not use the unit, and contact the supplier.



This symbol indicates "**Caution**" and is placed next to all safety warnings. Strictly follow these instructions in order to avoid danger and damage to persons, animals and things.



This symbol calls attention to a note or important notice



### **Certification**

The CE marking demonstrates that Ferroli gas units conform to the requirements contained in the applicable European directives.



<b>1. OPERATING INSTRUCTIONS.....</b>	<b>4</b>
1.1 Introduction .....	4
1.2 Control panel .....	4
1.3 Turning on and off .....	5
1.4 Adjustments .....	5
1.5 Maintenance.....	6
1.6 Anomalies.....	6



<b>2. INSTALLATION .....</b>	<b>7</b>
2.1 General Instructions.....	7
2.2 Place of installation .....	7
2.3 Plumbing connections.....	7
2.4 Gas connection .....	8
2.5 Electrical Connections .....	9
2.6 Connection to the flue.....	10
2.7 Installing module generators.....	10



<b>3. SERVICE AND MAINTENANCE.....</b>	<b>18</b>
3.1 Adjustments .....	18
3.2 System start-up .....	21
3.3 Maintenance.....	22
3.4 Troubleshooting.....	26



<b>4 TECHNICAL CHARACTERISTICS AND DATA.....</b>	<b>28</b>
4.1 Dimensions and connections .....	28
4.2 General view and main components .....	29
4.3 Technical data table.....	30
4.4 Diagrams .....	31
4.5 Wiring diagrams.....	32
<b>BENCHMARK .....</b>	<b>36</b>



# 1. OPERATING INSTRUCTIONS

## 1.1 Introduction

Dear Customer,

Thank you for choosing **Pegasus F3 N 2S**, a FERROLI floor-standing boiler featuring advanced design, cutting-edge technology, high reliability and quality construction. Please read this manual carefully and keep it for future reference.

**Pegasus F3 N 2S** is a high-efficiency heat generator for central heating running on natural or liquid gas and regulated by an advanced electronic control system.

The boiler shell consists of cast-iron elements whose particular shape guarantees high exchange efficiency under all operating conditions and an open-flue burner equipped with electronic ignition and ionization flame control.

The boiler outfit moreover includes an automatic boiler air vent valve, a 2-stage control thermostat and a safety thermostat.

Thanks to the electronic ignition and flame control system, unit operation is for the most part automatic.

The user only has to set the system temperature by means of the control thermostat.

## 1.2 Control panel

To access the control panel, lift the front door.

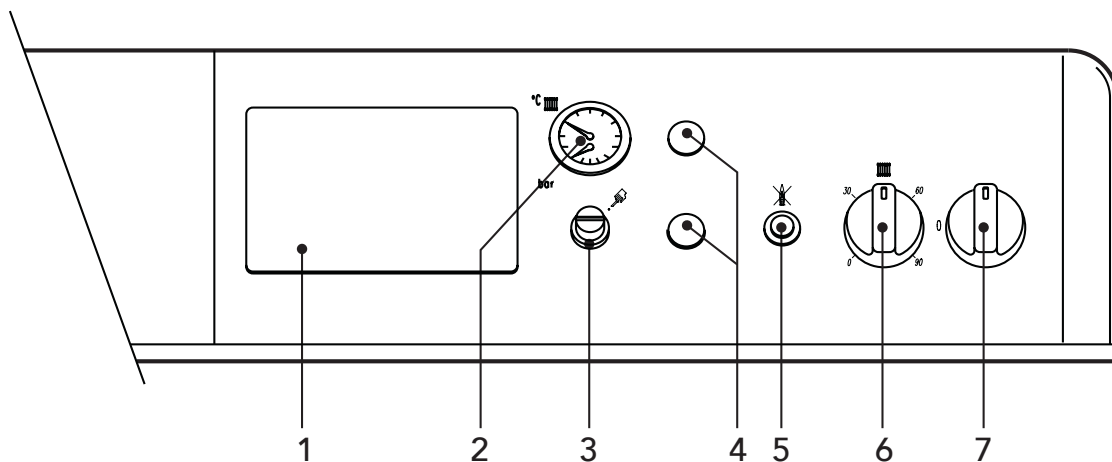

fig. 1

**Key**

- 1 Arrangement for thermostatic controller
- 2 Boiler pressure thermometer
- 3 Manual reset safety thermostat cover
- 4 Plug
- 5 Flame control reset button with block light
- 6 2-stage boiler control thermostat
- 7 0 - 1 - TEST switch



## 1.3 Turning on and off

### Ignition

- Open the gas valve ahead of the boiler.
- Turn on or insert any switch or plug ahead of the boiler
- Turn the boiler switch "7" onto 1 (Fig. 1).
- Turn knob "6" to the preselected temperature and any room thermostat to the desired temperature value. At this point, the burner will light and the boiler begins to function automatically, controlled by its adjustment and safety devices.
- If the boiler is equipped with an electronic thermostatic controller mounted at position 1 of Fig. 1, the user must also take into account the manufacturer's instructions.

 If, after correctly carrying out the lighting procedure, the burners do not light and the pushbutton light "5" comes on, wait about 15 seconds and then press the above-mentioned pushbutton. The flame controller reset in this way will then repeat the ignition cycle. If the burners do not light after a number of attempts, consult the anomalies paragraph.

 In case of an electrical power failure while the boiler is working, the burners will go out and re-ignite automatically when power is restored.

### Turning off

Close the gas cock ahead of the boiler, turn knob "7" onto the 0 position and disconnect the electrical power.

 To avoid damage caused by freezing during long shutdowns in winter, it is advisable to drain all water from the boiler and the system; or add a suitable antifreeze to the heating system. The boiler switch 7 has 3 positions, "0-1-TEST"; the first two have the on-off function, the third (unstable) must only be used for service and maintenance purposes.

## 1.4 Adjustments

### System temperature adjustment

Turn knob 6 (Fig. 1) clockwise to increase the heating water temperature, turn anticlockwise to decrease it. The temperature can be varied from a minimum of 30°C to a maximum of 90°C. However, it is advisable not to operate the boiler below 45°C.

### Room temperature adjustment (with optional room thermostat)

Using the room thermostat, set the temperature desired in the rooms. Controlled by the room thermostat, the boiler lights and delivers water to the system at the temperature set by boiler adjustment thermostat 6 (Fig. 1). The generator turns off when the desired temperature in the rooms is reached.

If the room thermostat is not installed the boiler will keep the system at the temperature set by the boiler control thermostat.

### Water system pressure adjustment

The filling pressure with system cold, read on boiler hydrometer (detail 2 in Fig.1), must be about 1.0 bar. If, during operation, the system pressure falls (caused by the evaporation of gas dissolved in the water) to values below the minimum described above, the user must bring it back to the initial value by operating the filling cock. At the end of the operation always close the filling cock.

## 1.5 Maintenance

The user must have the heating system serviced by qualified personnel at least once a year and combustion checked at least every two years. Consult chapter 3.3 of this manual for more information.





The boiler casing, panel and aesthetic parts can be cleaned with a soft damp cloth, possibly soaked in soapy water. Do not use any abrasive detergents and solvents.

## 1.6 Anomalies

Listed below are the anomalies that can be caused by simple, user-solvable problems.



Before calling the assistance service, check that the problem is not due to there being no gas or electricity.

Symbol	Fault	Cure
 	Boiler blocked by the flame controller	Make sure that the gas cocks ahead of the boiler and on the meter are open. Press the lit pushbutton-indicator light. In case of repeated shutdowns, contact the nearest assistance centre.
	Boiler shutdown due to insufficient system pressure (only if a water pressure switch is installed on the system)	Fill the system to 1-1.5 bar cold by means of the system filling cock. Close the cock after use.
 	Boiler shutdown due to water overtemperature	Unscrew the safety thermostat cover and press the button below. In case of repeated shutdowns, contact the nearest assistance centre.

## 2. INSTALLATION

### 2.1 General Instructions



This device must only be used for the purpose for which it is specially designed.

This unit is designed to heat water to a temperature below boiling point at atmospheric pressure and must be connected to a heating system and/or a water supply system for domestic use, compatible with its performance, characteristics and its heating capacity.

Any other use is considered improper.

**THE BOILER MUST ONLY BE INSTALLED BY QUALIFIED PERSONNEL, IN ACCORDANCE WITH ALL THE INSTRUCTIONS GIVEN IN THIS TECHNICAL MANUAL, THE PROVISIONS OF CURRENT LAW, ANY LOCAL REGULATIONS AND THE RULES OF PROPER WORKMANSHIP.**

Incorrect installation can cause damage or physical injury for which the manufacturer declines any responsibility.



### 2.2 Place of installation

This unit is an "open chamber" type and can only be installed and operated in permanently ventilated rooms. An insufficient flow of combustion air to the boiler will affect its normal operation and fume evacuation. Also, the fumes forming under these conditions (oxides) are extremely harmful to health if dispersed in the domestic environment.

Therefore the place of installation must be free of dust, flammable materials or objects or corrosive gases. The room must be dry and not subject to freezing.

When positioning the boiler, leave sufficient space around it for normal maintenance activities.



### 2.3 Plumbing connections

The heating capacity of the unit should be previously established by calculating the building's heat requirement according to current regulations. For good operation and long life of the boiler, the plumbing system must be well proportioned and always complete with all those accessories that guarantee regular operation and running.

If the delivery and return pipes follow a path where air pockets could form in certain places, it is advisable to install vent valves at these points. Also, install a discharge device at the lowest point in the system to allow its complete emptying.

If the boiler is installed at a lower level than the system, it is advisable to provide a flow-stop valve to prevent the natural circulation of system water.

The temperature drop between the delivery manifold and the return to the boiler should not exceed 20°C.



Do not use the water system pipes to earth electrical appliances.

Before installation, carefully wash all the pipes of the system to remove residues or impurities that could affect the unit's good working.

Make the connections to the corresponding connections as shown in Fig. 2.



It is advisable to install on-off valves between the boiler and heating system allowing the boiler to be isolated from the system if necessary.



Make the boiler connection in such a way that its internal pipes are free of stress.

Type and model	A	C	D	E	a1 Return Heating	a2 Delivery Heating	a3 Inlet gas
Pegasus F3 N 119 2S	930	220	50	42	2"	2"	1"
Pegasus F3 N 136 2S	1020	250	53	45	2"	2"	1"
Pegasus F3 N 153 2S	1100	250	58	43	2"	2"	1" 1/2
Pegasus F3 N 170 2S	1190	300	60	46	2"	2"	1" 1/2
Pegasus F3 N 187 2S	1270	300	58	44	2"	2"	1" 1/2
Pegasus F3 N 221 2S	1440	300	57	45	2"	2"	1" 1/2
Pegasus F3 N 255 2S	1610	350	62	46	2"	2"	1" 1/2
Pegasus F3 N 289 2S	1780	350	66	49	2"	2"	1" 1/2

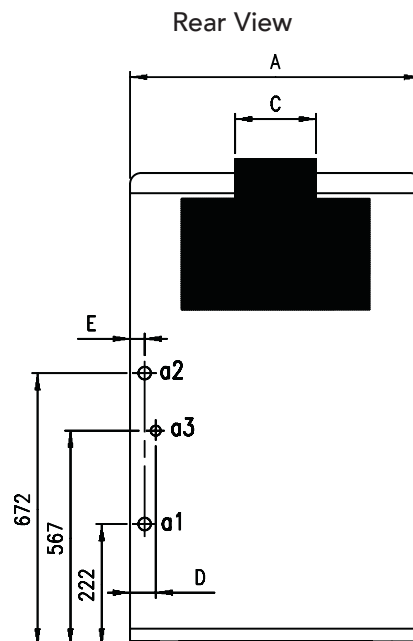

fig. 2

### Characteristics of the water system

In the presence of water harder than 25° Fr, we recommend the use of suitably conditioned water in order to avoid possible scaling in the boiler, caused by hard water, or corrosion produced by aggressive water. It should be remembered that, because of its low thermal conductivity, even scaling of just a few mm thick causes significant overheating of the boiler walls with consequent serious problems.

Water treatment is indispensable in the case of very large systems (containing large amounts of water) or with frequent introduction of replenishing water in the system. If partial or total emptying of the system becomes necessary under these conditions, it is advisable to refill it with treated water.

### Filling boiler and system

The filling pressure with system cold system must be about 1 bar. If, during operation, the system pressure falls (caused by evaporation of gas dissolved in the water) to a value below the minimum described above, the user must bring it back to the initial value. For correct operation of the boiler, when hot, its pressure must be about 1.5-2 bar.

## 2.4 Gas connection



Before making the connection, ensure that the unit is arranged for operation with the type of fuel available and carefully clean all the pipes of the gas system to remove any residues that could affect good functioning of the boiler.

The gas must be connected to the relative connector (see Fig. 2) in conformity with current standards, with rigid metal pipes or with continuous flexible s/steel wall tubing, placing a gas cock between the system and the boiler. Make sure that all the gas connections are tight.

The capacity of the gas meter must be sufficient for the simultaneous use of all equipment connected to it. The diameter of the gas pipe leaving the boiler does not determine the diameter of the pipe between the unit and the meter; it must be chosen according to its length and loss of head, in conformity with current standards.



Do not use the gas pipes to earth electrical appliances.



## 2.5 Electrical Connections

### Connection to the electrical grid

The boiler must be connected to a single-phase, 230 Volt-50 Hz electric line.



The unit's electrical safety is only guaranteed when correctly connected to an efficient earthing system executed according to current safety standards. Have the efficiency and suitability of the earthing system checked by professionally qualified personnel. The manufacturer is not responsible for any damage caused by failure to earth the system. Also make sure that the electrical system is adequate for the maximum power absorbed by the unit, as specified on the boiler dataplate, in particular ensuring that the section of the system's cables is suitable for the power absorbed by the unit.

The boiler is prewired and supplied with a connector located inside the control panel, arranged for connection to an electronic thermostatic controller (see wiring diagrams in paragraph 4.5). In addition, it is equipped with a three-pole cable for connection to the electricity line. The mains connections must be made with a permanent connection and equipped with a bipolar switch whose contacts have a minimum opening of at least 3 mm, interposing fuses of max. 3A between the boiler and the line. It is important to respect the polarities (LINE: brown wire / NEUTRAL: blue wire / EARTH: yellow-green wire) in making connections to the electrical line.

### Access to the electrical terminal board and internal components of the control panel

To access the electrical components inside the control panel, follow the sequence in Fig. 3 - 4 - 5 - 6.

The layout of the terminals for the various connections is given in the wiring diagrams in the technical data chapter.

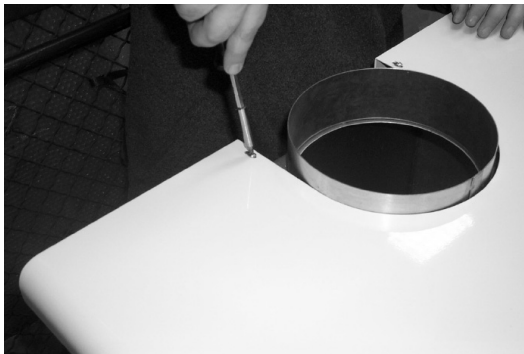

Fig. 3 - Unscrew the 2 self-tapped screws holding the boiler cover.



Fig. 4 - Lift by pressing upwards and take off the cover that is held at the sides of the boiler by pins.



Fig. 5 - Unscrew and take out the two screws and both plates holding the control panel.



Fig. 6 - Turn the control panel forwards.



Any additional sensitive elements of the system's control and safety devices, temperature sensor, pressure switch, thermostat bulb, etc., must be located on the delivery pipe within 40 cm. of the rear wall of the boiler casing (see Fig. 7).

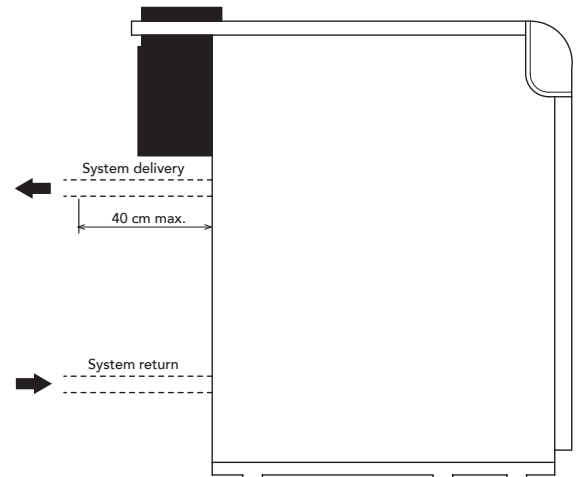

fig. 7

## 2.6 Connection to the flue

The diameter of the flue connection pipe must not be less than that of the connection on the anti-backflow device. Starting from the anti-backflow device it must have a vertical section at least 50 cm long. Current standards must be complied with regarding the dimensioning and installation of the flues and connection pipe.

The diameters of the anti-backflow device collars are given in the table of Fig. 2.

## 2.7 Installing module generators

INSTALLATION MUST ONLY BE PERFORMED BY QUALIFIED PERSONNEL, IN ACCORDANCE WITH ALL THE INSTRUCTIONS GIVEN IN THIS TECHNICAL MANUAL, THE PROVISIONS OF CURRENT LAW, THE PRESCRIPTIONS OF UNI AND CEI STANDARDS, ANY LOCAL REGULATIONS AND THE RULES OF PROPER WORKMANSHIP.

### General Warnings

It is advisable to install on-off valves between the boiler (module) and the system allowing the boiler to be isolated from the system if necessary. In this case each boiler must be fitted with a safety valve operating on the delivery pipe.

If the delivery and return pipes follow a path where air pockets could form in certain places, it is advisable to install vent valves at these points.

The heating water temperature drop, the difference between the system delivery and return temperature, must be lower than 20°C. To prevent condensation in the boiler and the associated damage.

Evacuate the products of combustion by means of a flue, whose cross-section must conform to current standards and anyhow be no less than that of the coupling to the module generator fume manifold. If it is wished to use manifolds to discharge the fumes, see the charts of Fig. 8 and 9.

All the couplings between the boiler and the flue must be airtight.

The capacity of the gas meter must be sufficient for the simultaneous use of all the generators connected to it.

Make the various boiler connections in such a way that their pipes are free of mechanical stress.

Make the gas connections of the single generators in accordance with current regulations.

## **Characteristics of the system water**

In the presence of water harder than 25° - 30° Fr, we recommend the use of suitably conditioned water for the heating system in order to avoid possible scaling in the boiler, caused by hard water, or corrosion produced by aggressive water. It should be remembered that, because of its low thermal conductivity, even scaling of just a few mm thick causes significant overheating of the boiler walls with consequent serious problems.

**Water treatment is indispensable for the heating system in the following cases:**

**A) very large systems (containing large amounts of water):**

**B) frequent introduction of replenishing water in the system, in the case of draining the system either partially or totally.**

## **Positioning the module generators and connecting the flues to the manifold**

The set of module generators can comprise at most 4 units; depending on controller requirements they can be arranged with the modules either facing each other or in a line.

Position the generators and connect the fume extraction pipes according to the diagrams and data given in the charts of Fig. 8 - 9. Seal the various pipe joints.



HEAT GENERATORS WITH FACING MODULES COMPREHENSIVE OF FUME DUCTING CHAMBER										
SIDE VIEW	PLAN VIEW 2 MODULES			PLAN VIEW 3 MODULES			PLAN VIEW 4 MODULES			
	Output kW	Heating power kW	L	H	Ø	Output kW	Heating power kW	L	H	Ø
<p>F = 2200 mm 8 - 14 el 2300 mm 16 - 18 el</p>	<b>238</b>	262.0	930	1775	300	<b>357</b>	393.0	1960	1825	400
	<b>272</b>	298.0	1020	1800	350	<b>408</b>	447.0	2140	1850	450
	<b>306</b>	336.0	1100	1800	350	<b>459</b>	504.0	2300	1850	450
	<b>340</b>	374.0	1190	1850	450	<b>510</b>	561.0	2480	1900	550
	<b>374</b>	412.0	1270	1850	450	<b>561</b>	618.0	2640	1900	550
	<b>442</b>	486.0	1440	1850	450	<b>663</b>	729.0	2980	1900	550
	<b>510</b>	560.0	1610	1875	500	<b>765</b>	840.0	3320	1925	600
	<b>578</b>	628.0	1780	1875	500	<b>867</b>	951.0	3660	1925	600
<b>STANDARD BOILER</b>	<b>Output kW</b>	<b>Heating power kW</b>	<b>L</b>	<b>H</b>	<b>Ø</b>	<b>Output kW</b>	<b>Heating power kW</b>	<b>L</b>	<b>H</b>	<b>Ø</b>
<b>PEGASUS F3 N 119 2S</b>	<b>238</b>	262.0	930	1775	300	<b>357</b>	393.0	1960	1825	400
<b>PEGASUS F3 N 136 2S</b>	<b>272</b>	298.0	1020	1800	350	<b>408</b>	447.0	2140	1850	450
<b>PEGASUS F3 N 153 2S</b>	<b>306</b>	336.0	1100	1800	350	<b>459</b>	504.0	2300	1850	450
<b>PEGASUS F3 N 170 2S</b>	<b>340</b>	374.0	1190	1850	450	<b>510</b>	561.0	2480	1900	550
<b>PEGASUS F3 N 187 2S</b>	<b>374</b>	412.0	1270	1850	450	<b>561</b>	618.0	2640	1900	550
<b>PEGASUS F3 N 221 2S</b>	<b>442</b>	486.0	1440	1850	450	<b>663</b>	729.0	2980	1900	550
<b>PEGASUS F3 N 255 2S</b>	<b>510</b>	560.0	1610	1875	500	<b>765</b>	840.0	3320	1925	600
<b>PEGASUS F3 N 289 2S</b>	<b>578</b>	628.0	1780	1875	500	<b>867</b>	951.0	3660	1925	600

fig. 8



### **Electrical connection of module generators**

Each generator comprising the modular assembly is supplied pre-wired for both the adjustments and the safety devices. It can therefore operate on its own (see wiring diagrams of paragraph 4.5). Connect each generator to a single-phase electric line of 230 V ~ 50 Hz, neutral phase, via a terminal board or regular plug, inserting fuses max. 2 A between the boiler and the line.

It is always important to connect each generator to a good earthing system.

If you want the generators forming the modular assembly to work in cascade, you will need to use an electronic sequence controller.

### **Electronic sequence controller (supplied on request)**

Each generator forming the modular assembly is fitted for installing an electronic sequence controller (Fig. 10) that can be secured to the instrument panel by simply removing the plug 1 (Fig. 1). To access the components inside the instrument panel, see paragraph 2.5.



A single sequence controller is needed for each set of module generators.

**The instructions manual for connecting, adjusting and programming the electronic sequence controller as well as for the various types of system is contained in the controller package.**

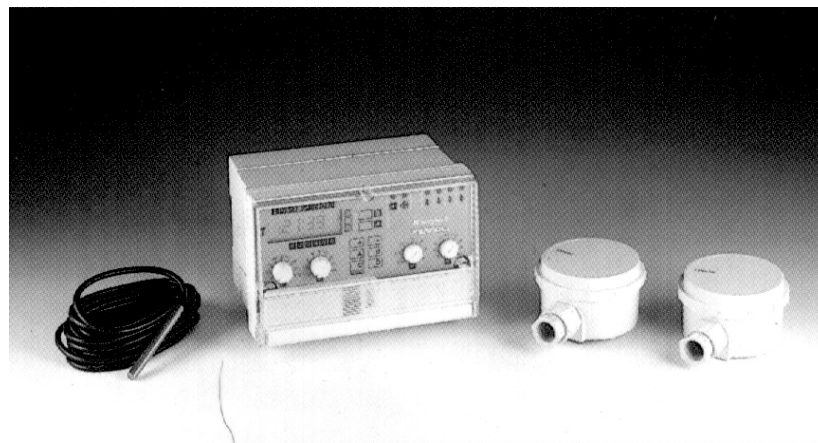

fig. 10

### **Fundamental functions of the electronic sequence controller**

- Reduction interlocked with outside temperature (climate control).
- Programming on two different temperature levels (economy and comfort).
- Daily programming with up to three actions on one level and three on the other.
- Setting the daily program for the whole week.
- Rotating the action sequence every 24 hours to distribute module wear.
- Smart forced starting.
- Smart ON-OFF time control in the action cycle.
- Checking pump starting according to the outside temperature.
- Self-diagnosis for malfunctioning.

## Application systems

The 2 application systems are described here.

### System 1: 4 modular generators with no hot water production

#### Application

Direct delivery heating with at most 4 modular generators.

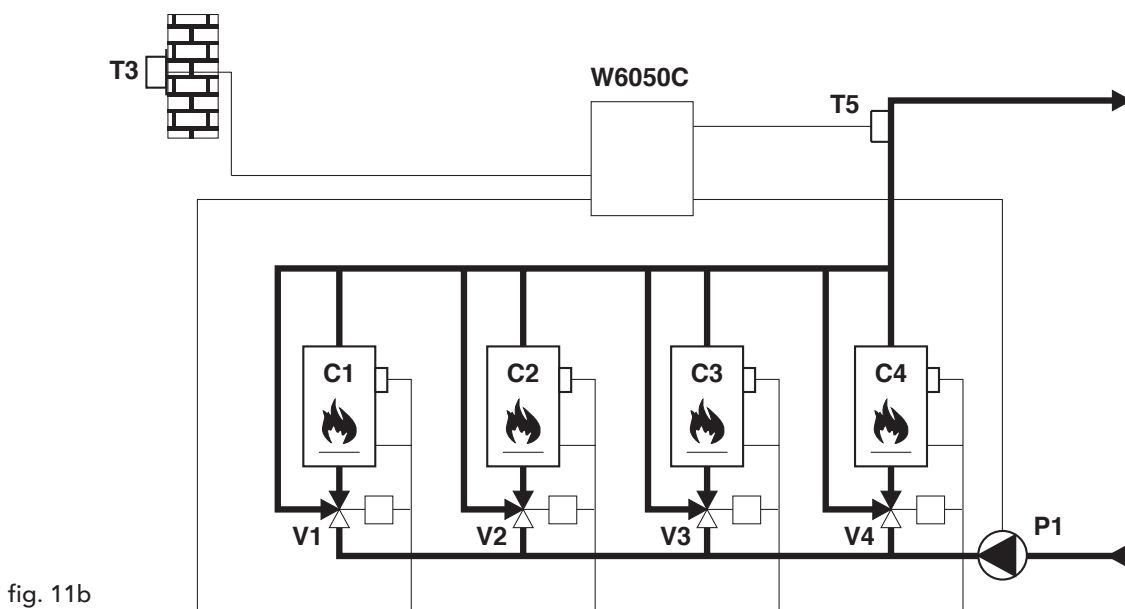
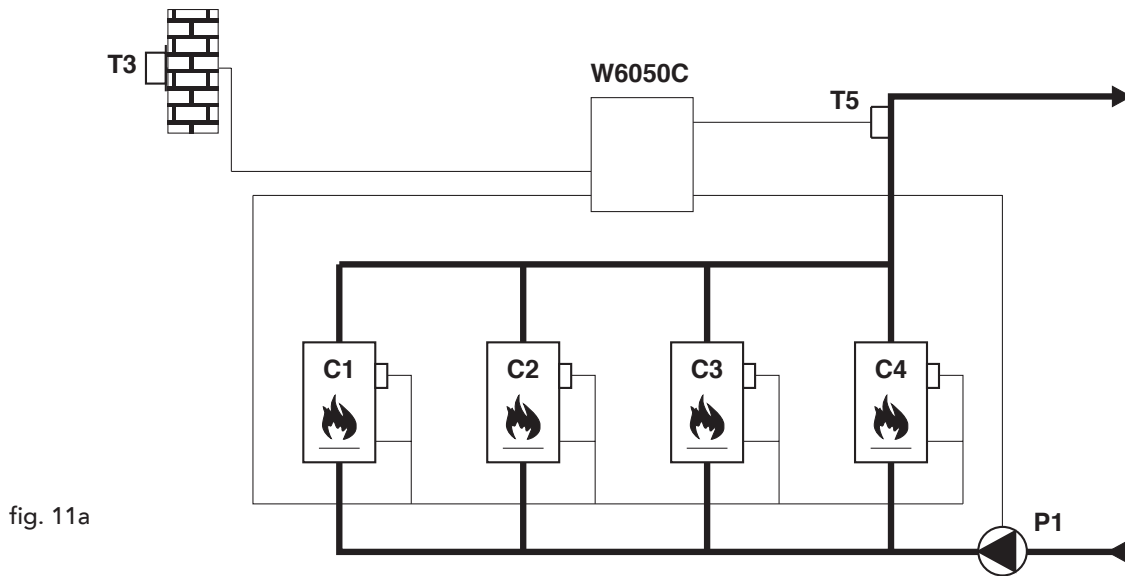

#### Key:

- C1 - C2 - C3 - C4 = Modular generators
- V1 - V2 - V3 - V4 = 3-way valves
- T5 = Delivery manifold sensor
- T3 = External sensor
- P1 = Heating circulation pump

**System 2: 4 modular generators with hot water production**

**Application**

Direct delivery heating with at most 4 modular generators with hot water production via diverter valve.

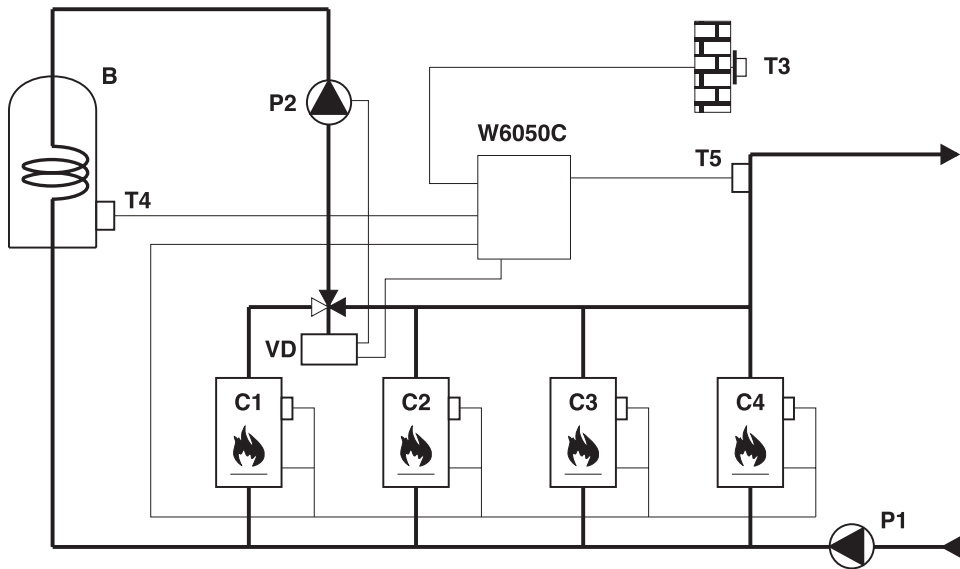

fig. 12a

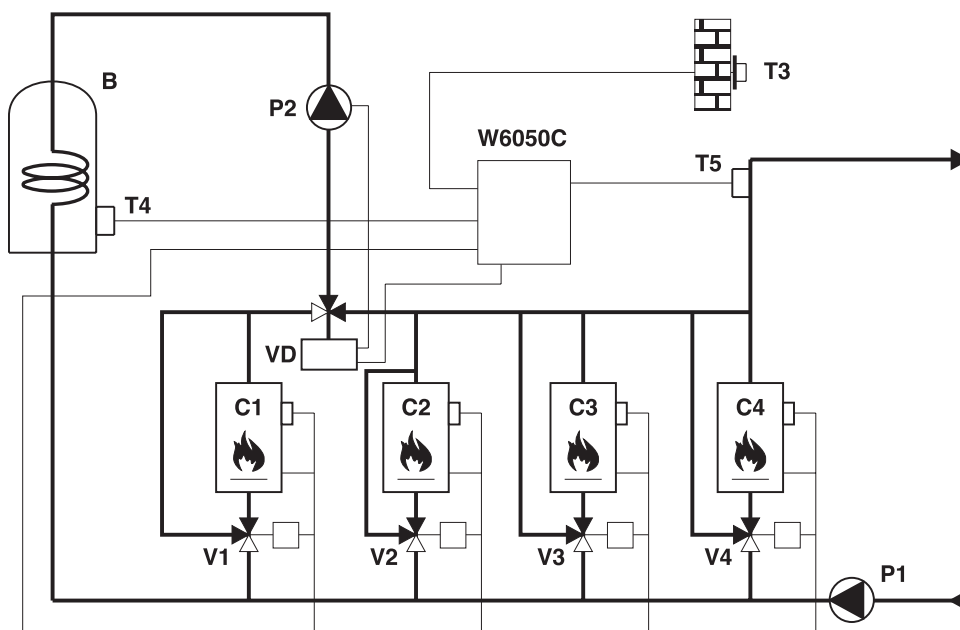

fig. 12b

**Key:**

C1 - C2 - C3 - C4 = Modular generators

V1 - V2 - V3 - V4 = 3-way valves

B = Boiler

VD = Diverter valve

T3 = External sensor

T4 = Modular generators

T5 = Delivery manifold sensor

P1 = Heating circulation pump

P2 = Boiler circulation pump

When the system is producing water for domestic use the sequence governor will always control just one generator for this function, which in the diagrams of Fig. 12a - 12b is C1



## Control and check panel for module generators in sequence (supplied on request)

In order to make the electric connection between the four-stage sequence governor W6050C, the module generators **PEGASUS F3 N 2S** and the various system components more straightforward and functional, we have made a control and check panel for heating plants.

It is supplied pre-wired and comprehensive of sequence governor, fuse, indicator lamps, and switches making it possible to check and select every possible system of using the sequence governor W6050C.

The panel, which contains the terminal blocks to connect sensors, pumps, diverter valve and generators in sequence, is supplied together with cable clamps.

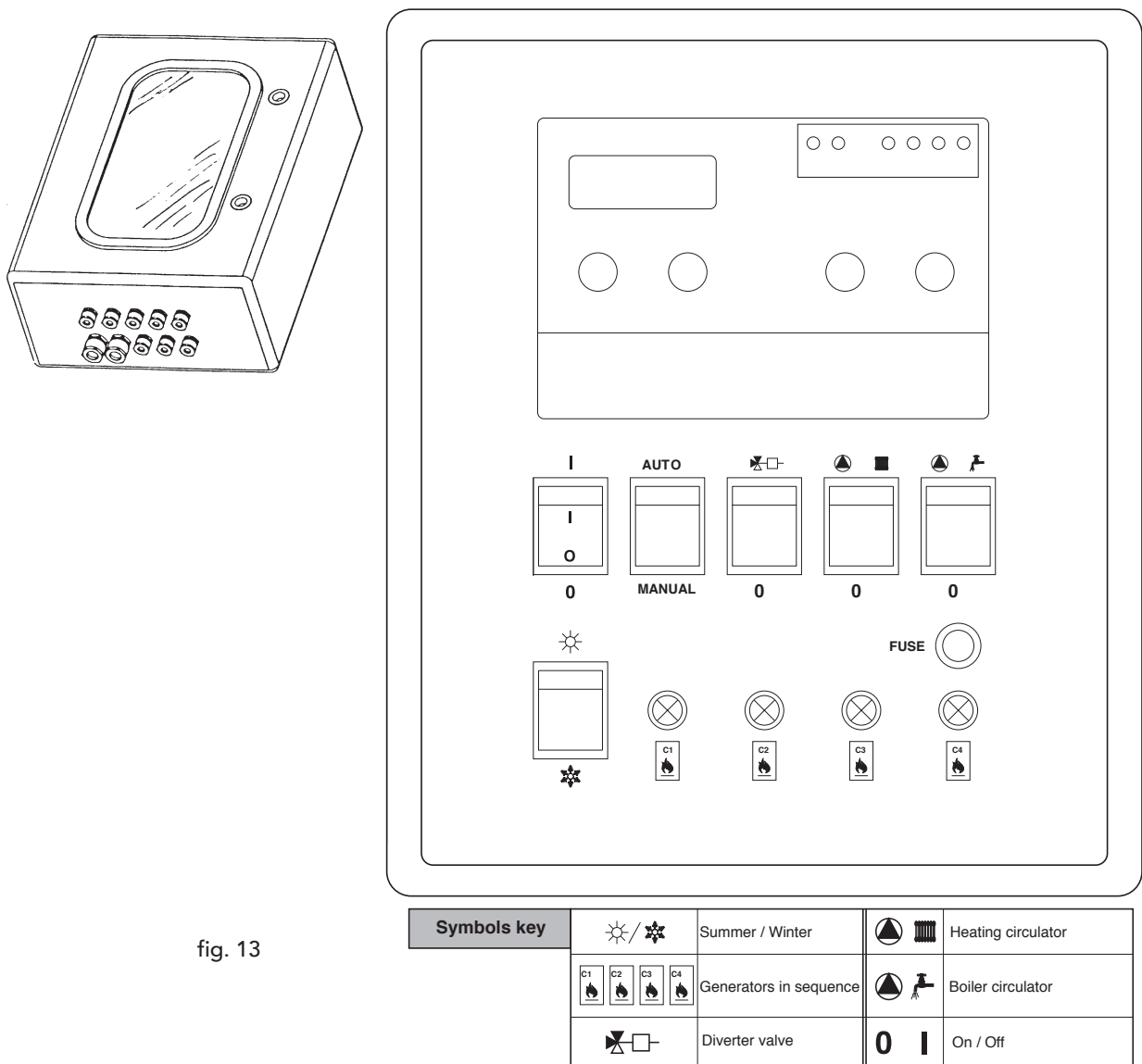

fig. 13

### Panel specifications:

- Dimensions 310x420x h 150
- Protection rating IP 65
- Twin key door locking
- Cable clamps: No.8 PG9 + No.2 PG13.5

## 3. SERVICE AND MAINTENANCE

### 3.1 Adjustments

All adjustment and conversion operations must be carried out by Qualified Personnel.

The manufacturer declines any responsibility for damage or physical injury caused by unqualified and unauthorized persons tampering with the device.

#### **Adjusting the burner gas pressure**

The **Pegasus F3 N 2S** boilers are made to burn natural or liquid gas. The pressure setting and test are performed in the factory.

However, as there may be changes in supply pressure, at the time of the first ignition it will be necessary to check and perhaps adjust the pressure at the nozzles, observing the values given in the technical data chart in paragraph 4.3.

The operations for adjusting the pressure are performed with the boiler working, using the pressure control on the 2-stage gas valves (see Fig. 14).

#### **Preliminary operations:**

- 1 Ignite the boiler and turn the control thermostat knob onto minimum.
- 2 Connect a pressure gauge to the pressure point on the gas manifold pipe of the burner assembly (see part 14 in Fig. 24).
- 3 Take off the cover protecting the pressure regulator 4 (Fig. 14).

#### **Adjusting the minimum power (1st stage)**

- 1 Slowly turn the adjustment thermostat knob clockwise as far as the 1st click; the gas valve will thus be supplied solely on connections A and B (see Fig. 14).
- 2 Turn the screw 6 (Fig. 14), checking that the pressure corresponds to the values of the technical data chart in paragraph 4.3.

#### **Adjusting the maximum power (2nd stage)**

- 1 Turn the adjustment thermostat knob onto maximum; the gas valve will now be supplied on connections A, B and C (see Fig. 14).
- 2 Turn the screw 5 (Fig. 14), checking that the pressure corresponds to the values of the technical data chart in paragraph 4.3.

The adjustment operations must be performed uniformly on the pressure regulators of all the valves.

 The gas pressures measured at the burner gas manifold should be read at least 30 seconds after making the adjustments, i.e. when the flame has stabilized.

On completing the adjustment operations, turn the burner on and off 2 - 3 times with the adjustment thermostat and check that the pressure values are the ones you have just set; if this is not so, you need to make another adjustment to bring the pressures to the right values.

#### **Gas supply conversion**

The unit can function with either Natural gas (G20) or liquid gas (G30-G31) and is factory-set for use with one of the two gases, as clearly shown on the packing and dataplate. Whenever the unit has to be used with a different gas, a conversion kit will be required, proceeding as follows:

## From natural to liquid gas

- 1 Replace the nozzles at the main burner and pilot light, inserting the nozzles specified in the technical data table in chap. 4.3.
- 2 Remove the small plug 3 (Fig. 14) from the gas valve, screw the ignition "STEP" regulator 2, contained in the conversion kit, onto the valve and put the plug 3 back onto the regulator.
- 3 Adjust the burner gas pressures, for minimum and maximum power as described in the above paragraph, setting the values given in the technical data chart in paragraph 4.3.
- 4 Operations 2 and 3 must be performed on all the valves.
- 5 Apply the sticker, contained in the conversion kit, near the dataplate as proof of the conversion.

## From liquid to natural gas

Carry out the same operations explained above, taking care to remove the ignition "STEP" regulator 2 (Fig. 14) of the gas valve; the plug 3 (Fig. 14) must be fitted straight onto the valve.



Opening the safety cap

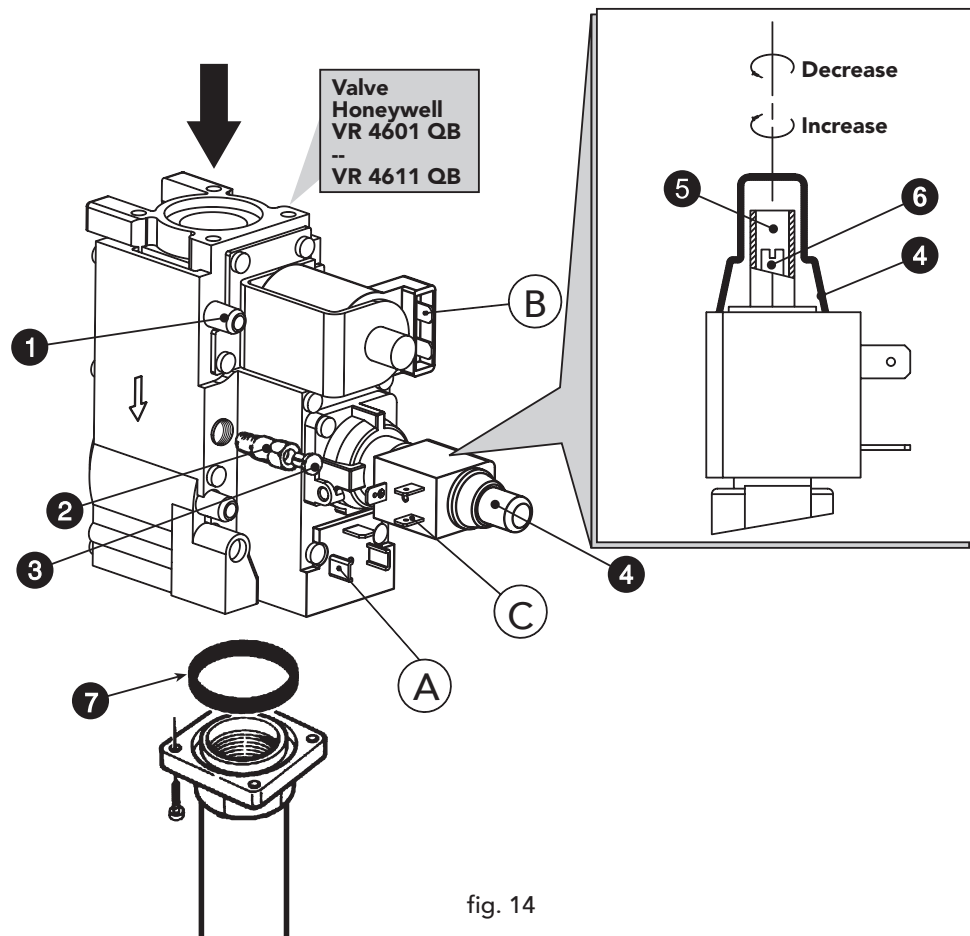
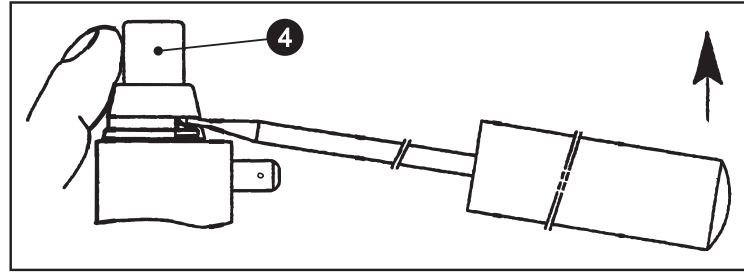



fig. 14

**Main components key**

- 1 Pressure point upstream from the valve
- 2 Ignition "STEP" regulator for liquid gas
- 3 Plug
- 4 Safety cap
- 5 Pressure adjustment screw for maximum power
- 6 Pressure adjustment screw for minimum power (1st stage)
- 7 "O RING"

**Electrical connections key**

- A+B** = Connections powered for minimum power (1st stage)
- A+B+C** = Connections powered for maximum power (2nd stage)

 To measure the burner gas pressure, use the pressure point on the gas manifold pipe of the burner assembly (see part 14 in Fig. 24)

## 3.2 System start-up



System start-up must be carried out by Qualified Personnel.

The following operations and checks are to be made at the first ignition, and after all maintenance work that involved disconnecting from the systems or work on safety devices or parts of the boiler.

### **Before lighting the boiler:**

- Open any on-off valves between the boiler and the system.
- Check the airtightness of the gas system, proceeding with caution and using a soap and water solution to detect any leaks in connections.
- Fill the water system and make sure that all air contained in the boiler and the system has been vented by opening the air vent valve on the boiler and any vent valves on the system.
- Make sure there are no water leaks in the system or boiler.
- Make sure the electrical system is properly connected.
- Make sure that the unit is connected to a good earthing system.
- Make sure that the pressure and gas flow values are those required for heating.
- Make sure there are no flammable liquids or materials in the immediate vicinity of the boiler.

### **Lighting the boiler**

- Open the gas valve ahead of the boiler.
- Vent the air from the pipe ahead of the gas valve.
- Turn on or insert any switch or plug ahead of the boiler.
- Turn the boiler switch (pos. 7 - Fig. 1) onto 1.
- Turn knob 6 (Fig. 1) to a value above 50°C and that of a possible room thermostat to the desired temperature value. At this point, the burner will light and the boiler begins to function automatically, controlled by its adjustment and safety devices.



If, after correctly carrying out the lighting procedure, the burners do not light and the pushbutton light comes on, wait about 15 seconds and then press the above-mentioned pushbutton.

The reset controller will repeat the ignition cycle. If the burners do not light after the second attempt, consult paragraph 3.4 "Troubleshooting."

The boiler switch 7 has 3 positions, "0-1-TEST"; the first two have the on-off function, the third (unstable) must only be used for service and maintenance purposes.



In case of an electrical power failure while the boiler is working, the burners will go out and re-ignite automatically when power is restored.

### **Checks during operation**

- Check the airtightness of the fuel circuit and water systems.
- Check the efficiency of the flue and fume ducts while the boiler is working.
- Check that the water is circulating properly between the boiler and the systems.
- Check the proper ignition of the boiler by performing various tests, turning it on and off with the room thermostat or boiler thermostat.
- Make sure that the fuel consumption indicated on the meter corresponds to that given in the technical data table in chap. 4.



### **Turning off**

To temporarily turn the boiler off, just turn the boiler switch 7 (Fig. 1) onto 0.

To turn the boiler off for an extended period:

- Turn the knob of the boiler switch 7 (Fig. 1) onto 0;
- Close the gas cock ahead of the boiler;
- Disconnect the electrical power to the unit;



To avoid damage caused by freezing during long shutdowns in winter, it is advisable to drain all water from the boiler and the system; or add a suitable antifreeze to the heating system.

## **3.3 Maintenance**



The following operations must only be carried out by Qualified Personnel.

### **Seasonal inspection of the boiler and flue**

It is advisable to carry out the following checks at least once a year:

- The control and safety devices (gas valve, thermostats, etc.) must function correctly.
- The fume ducts must be free of obstructions and leaks.
- The gas and water systems must be airtight.
- The burner and boiler shell must be clean. Follow the instructions in the next paragraph.
- The electrodes must be free of scale and properly positioned (see Fig. 21).
- The water pressure in the cold water system must be about 1 bar; otherwise, bring it to that value.
- The expansion tank, if present, must be filled.
- The gas flow and pressure must correspond to that given in the respective tables.
- The circulating pumps must not be blocked.

### **Safety devices**

The **Pegasus F3 N 2S** boiler is equipped with devices that guarantee safety in the event of operating trouble.

### **Temperature limiter (safety thermostat) and manual reset**

This device prevents the water temperature in the system from exceeding boiling point. The maximum intervention temperature is 110°C.

Reset of the temperature limiter can only occur with cooling of the boiler (the temperature must drop by at least 10°C) and identification and consequent elimination of the problem that caused the shutdown. To reset the temperature limiter you will need to unscrew the cover 3 (Fig. 1) and press the button below.

## Opening the front panel

To open the front panel of the boiler, see the sequence in Fig. 15.

 Before carrying out any operation inside the boiler, disconnect the electrical power supply and close the gas cock upstream.



fig. 15

## Combustion analysis

A point for sampling fumes has been included inside the boiler in the upper part of the anti-backflow device (see Fig. 16).

To take the sample:

- 1) Remove the top panel of the boiler (see Fig. 4).
- 2) Remove the insulation on the anti-backflow device.
- 3) Open the fume sampling point;
- 4) Insert the probe;
- 5) Adjust the boiler temperature to the maximum.
- 6) Wait 10-15 minutes for the boiler to stabilize\*
- 7) Take the measurement.

 \* Analyses made with an unstabilized boiler can cause measurement errors.

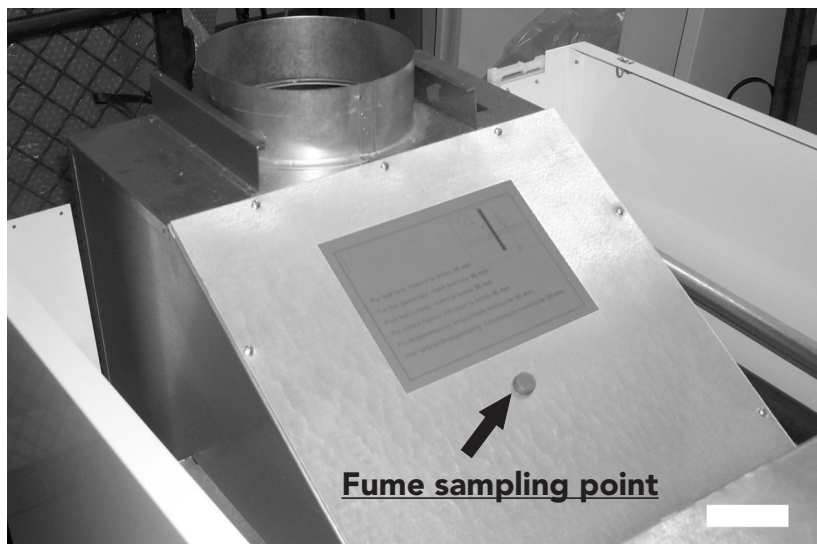

fig. 16



## Disassembly and cleaning the burner unit

to remove the burner unit:

- Disconnect the electrical power supply and turn off the gas ahead of the boiler.
- Unscrew the two screws securing the electronic flame controller to the gas valve (Fig. 17) and extract it from this valve (Fig. 18).
- Unscrew the screws securing the connectors to the gas valves (see Fig. 14) and extract them from these valves.
- Disconnect the ignition and ionization cables from the electrode unit;
- Unscrew the nuts securing the gas supply pipe upstream from the gas valves (Fig. 19).
- Unscrew the two nuts attaching the combustion chamber door to the cast iron elements of the boiler (Fig. 20).
- Remove the burner assembly and combustion chamber door.

At this point, check and clean the burners. Only use a non-metallic brush or compressed air to clean the burners; never use chemical products.

On completion, fit it all back together in reverse order.

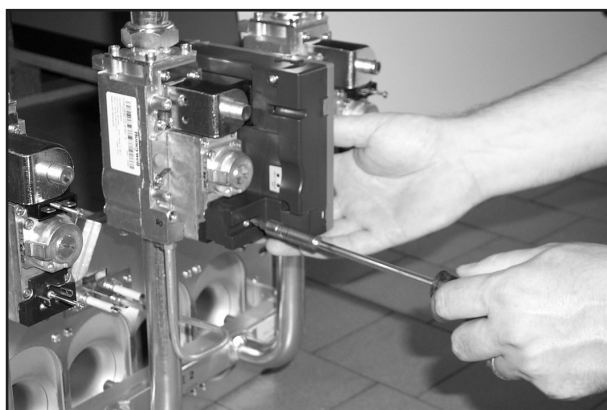

fig. 17

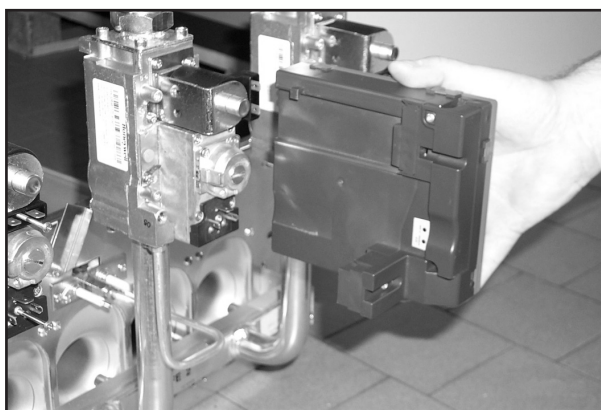

fig. 18



fig. 19



fig. 20



## Pilot light unit

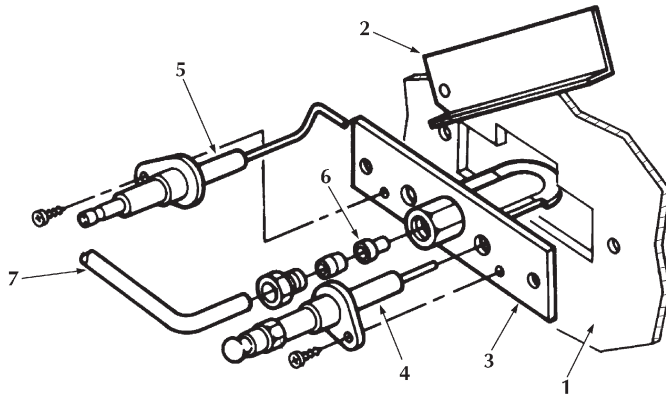

### Key

- 1 Combustion chamber door
- 2 Inspection door
- 3 Pilot burner
- 4 Ignition electrode
- 5 Detection electrode
- 6 Pilot nozzle
- 7 Gas supply pipe

fig. 21

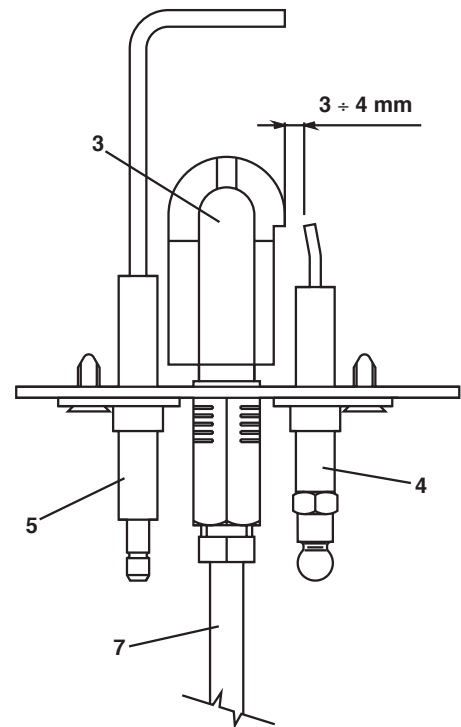

## Cleaning the boiler and flue

To clean the boiler properly (Fig. 22):

- Turn off the gas ahead of the unit and disconnect the electrical power supply.
- Take the front panel off the boiler (see Fig. 15).
- Lift the boiler cover by pressing upwards (see also Fig. 3-4).
- Remove the insulation covering the anti-backflow device.
- Remove the fume chamber closing plate and the associated insulation.
- Remove the burner unit (see preceding paragraph).
- Using the brush provided, clean the fume evacuation ducts between the cast iron elements of the boiler casing, lastly removing the dirt with a vacuum cleaner.
- Carefully reassemble all the previously disassembled parts and check the airtightness of the gas circuit and the combustion ducts.
- During cleaning operations take care not to damage the fume thermostat bulb mounted on the back of the fume chamber.

### Key

- 1 Screws securing the boiler cover
- 2 Boiler cover
- 3 Fume chamber closing plate
- 4 Fume chamber insulation
- 5 Brush
- 6 Combustion analysis plug

fig. 22

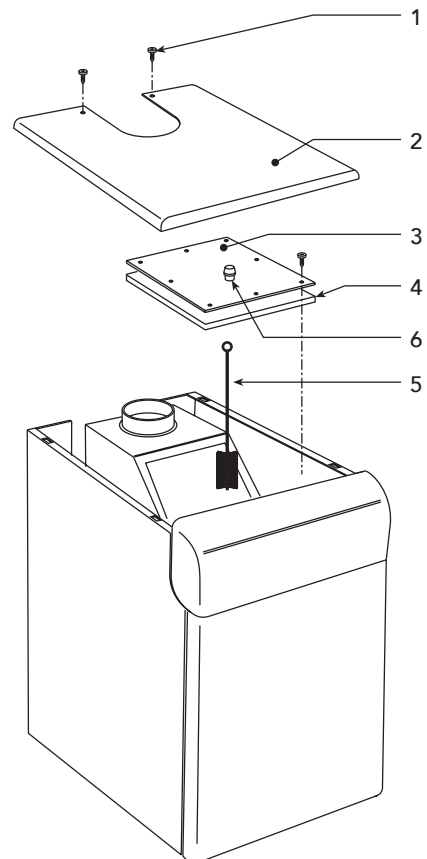

## 3.4 Troubleshooting

### Fault

Cause and cure.



#### **After a few attempts at ignition, the electronic controller shuts down the boiler.**

Pilot light nozzle dirty - Clean with compressed air.

Check the regular gas flow to the boiler and the air has been eliminated from the pipes.

Check that the electrodes are correctly positioned and free of any deposits (see fig. 21).

Make sure that the boiler is connected to a good earth connection.

Check the connections to the ignition and ionization electrodes.

#### **The electrodes are not discharging in the ignition phase.**

Check that the electrodes are correctly positioned and free of any deposits (see fig. 21).

Regulation thermostat adjusted too low.

Check the electrical power supply.

Check the connections to the ignition and ionization electrodes.

Check the connections at the electronic flame controller.

Make sure that PHASE and NEUTRAL are not inverted and that the earth contacts are efficient.

Check the inlet gas pressure and any open pressure switches.

Reset the safety thermostat.

Reset the fume thermostat.

Make sure the room thermostat is closed.



#### **The burner burns poorly: flames too high, too low or too yellow.**

Gas valve filter dirty.

Check the gas supply pressure.

Gas nozzles dirty.

Make sure that the boiler is not dirty.

Make sure that ventilation in the room where the unit is located is sufficient for good combustion.

#### **Smell of unburnt gas.**

Make sure that the boiler is clean.

Check the draught of the flue.

Check that gas consumption is not excessive.



#### **The boiler works but the temperature fails to increase.**

Check the 2-stage adjustment thermostat works properly.

Check that the operator of the 2nd stage of the gas valve (full power) is supplied (see Fig. 14).

Check that gas consumption is not less than that provided for.

Make sure that the boiler is perfectly clean.

Check that the boiler is adequate for the system.

Check that the heating pump is not blocked.

#### **Temperature of the water to the system too high or too low.**

Check the 2-stage adjustment thermostat works properly.

Check that the pump is not blocked.

Make sure that the characteristics of the circulating pump are adequate for the system.



**Burner explosion. Delay on ignition.**

Check that the gas pressure is sufficient and the boiler casing is not dirty.

**The adjustment thermostat switches back on with too great a temperature difference.**

Check that the thermostat bulb is properly inserted in the sheath.

Check the 2-stage thermostat works properly.

**The boiler produces condensation water.**

Check that the boiler is not operating at too low a temperature (below 50°C).

Check that gas consumption is regular.

Check the efficiency of the flue.

**The boiler goes out for no apparent reason.**

Fume thermostat trips.

Safety thermostat trips due to temperature rise.

**N.B.** To avoid unnecessary expense, before calling the Technical Assistance Service make sure that the boiler has not stopped due to no electricity or gas.



# 4 TECHNICAL CHARACTERISTICS AND DATA

## 4.1 Dimensions and connections

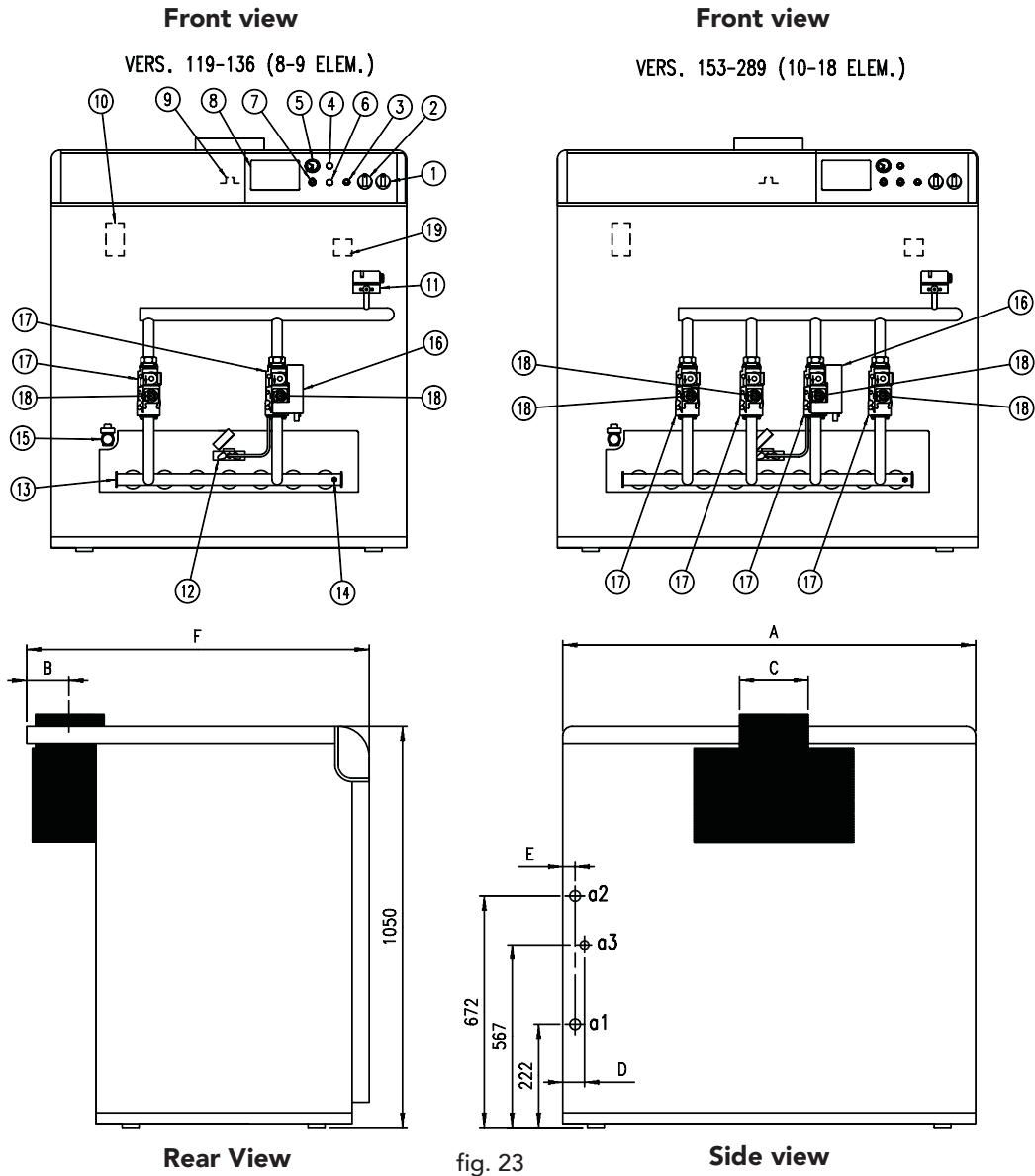

fig. 23

Type and model	A	B	C	D	E	F	⊕ a1 Return Heating	⊕ a2 Delivery Heating	⊕ a3 Inlet gas
Pegasus F3 N 119 2S	930	133	220	50	42	1050	2"	2"	1"
Pegasus F3 N 136 2S	1020	148	250	53	45	1050	2"	2"	1"
Pegasus F3 N 153 2S	1100	148	250	58	43	1050	2"	2"	1" 1/2
Pegasus F3 N 170 2S	1190	173	300	60	46	1050	2"	2"	1" 1/2
Pegasus F3 N 187 2S	1270	173	300	58	44	1050	2"	2"	1" 1/2
Pegasus F3 N 221 2S	1440	173	300	57	45	1050	2"	2"	1" 1/2
Pegasus F3 N 255 2S	1610	198	350	62	46	1100	2"	2"	1" 1/2
Pegasus F3 N 289 2S	1780	198	350	66	49	1100	2"	2"	1" 1/2

## 4.2 General view and main components

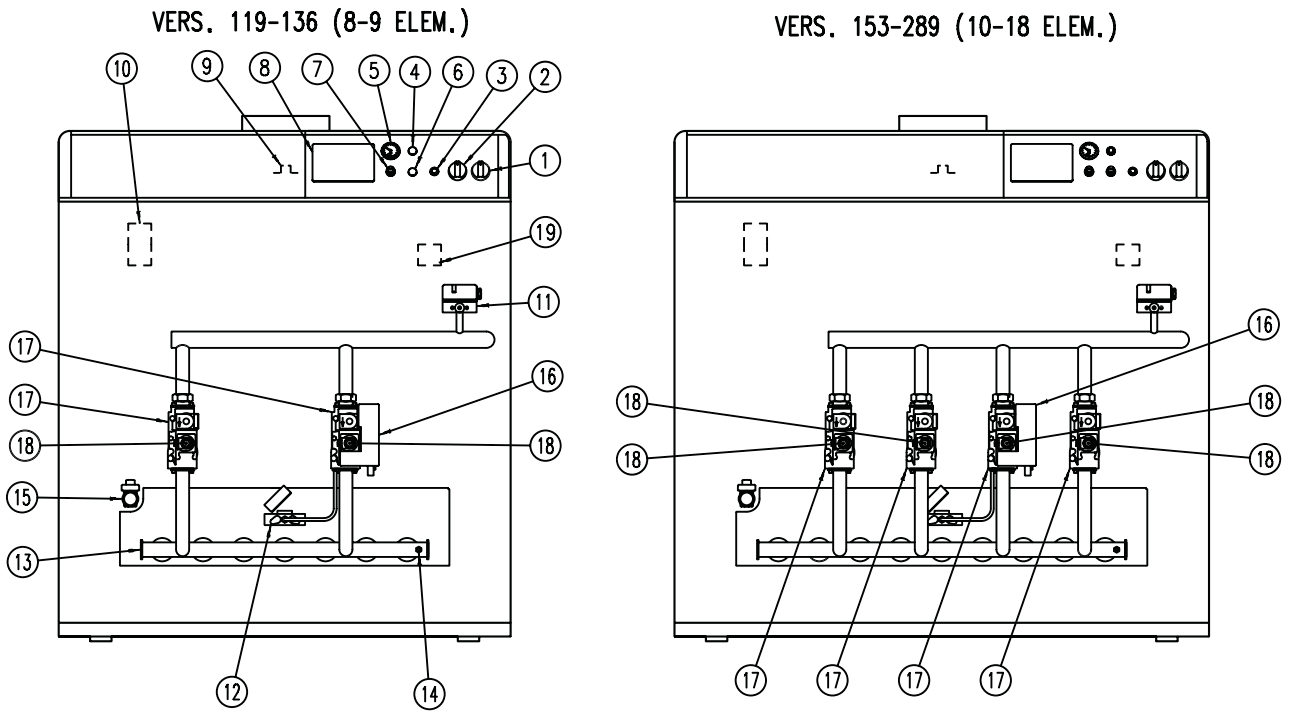

fig. 24

### Key

- 1 "0 - 1 - TEST" switch
- 2 2-stage adjustment thermostat
- 3 Electronic controller reset button
- 4 Plug
- 5 Thermometer water gauge
- 6 Plug
- 7 Safety thermostat
- 8 Arrangement for fitting an electronic controller
- 9 Fume outlet on fume chamber
- 10 Automatic air vent valve
- 11 Gas pressure switch
- 12 Pilot burner together with electrodes
- 13 Gas manifold
- 14 Pressure point
- 15 Discharge cock
- 16 Electronic flame controller
- 17 Gas valve
- 18 2nd stage operator
- 19 Water pressure switch

## 4.3 Technical data table

MODEL	119		136		153		170		187		221		255		289	
Powers	Pmax	Pmin	Pmax	Pmin	Pmax	Pmin	Pmax	Pmin	Pmax	Pmin	Pmax	Pmin	Pmax	Pmin	Pmax	Pmin
Heating Power (Net Heat Value - Hi)	kW	131	77	149	89	100	187	110	206	122	243	144	280	166	317	188
Useful heating power	kW	119	71	136	82	92	170	102	187	112	221	133	255	153	289	173
<b>Gas supply</b>																
Pilot nozzle G20	mm	1 x 0,40	1 x 0,40	1 x 0,40	1 x 0,40	1 x 0,40	1 x 0,40	1 x 0,40	1 x 0,40	1 x 0,40	1 x 0,40	1 x 0,40	1 x 0,40	1 x 0,40	1 x 0,40	1 x 0,40
Pilot nozzle G31	mm	1 x 0,24	1 x 0,24	1 x 0,24	1 x 0,24	1 x 0,24	1 x 0,24	1 x 0,24	1 x 0,24	1 x 0,24	1 x 0,24	1 x 0,24	1 x 0,24	1 x 0,24	1 x 0,24	1 x 0,24
Main nozzles G20	mm	7 x 3,40	8 x 3,40	8 x 3,40	9 x 3,40	10 x 3,40	10 x 3,40	10 x 3,40	11 x 3,40	11 x 3,40	13 x 3,40	13 x 3,40	15 x 3,40	15 x 3,40	17 x 3,40	17 x 3,40
Feed pressure G20	mbar	20,0	20,0	20,0	20,0	20,0	20,0	20,0	20,0	20,0	20,0	20,0	20,0	20,0	20,0	20,0
Pressure at burner G20	mbar	13,3	4,8	13,3	4,8	13,3	4,8	12,5	12,5	4,8	12,5	4,8	12,5	4,8	12,5	4,8
Delivery G20	nm <sup>3</sup> /h	13,8	8,1	15,8	9,4	17,9	10,6	19,8	21,8	12,9	25,7	15,2	29,6	17,6	33,5	19,9
Main nozzles G31	mm	7 x 2,15	8 x 2,15	8 x 2,15	9 x 2,15	10 x 2,15	10 x 2,15	10 x 2,15	11 x 2,15	11 x 2,15	13 x 2,15	13 x 2,15	15 x 2,15	15 x 2,15	17 x 2,15	17 x 2,15
Supply pressure G31	mbar	37,0	37,0	37,0	37,0	37,0	37,0	37,0	37,0	37,0	37,0	37,0	37,0	37,0	37,0	37,0
Pressure at burner G31	mbar	36	11,4	36	11,4	36	11,4	34	34	11,4	34	11,4	34	11,4	34	11,4
Delivery G31	kg/h	10,26	6,0	11,66	6,9	13,2	7,8	14,64	16,31	9,5	19,0	11,2	21,92	12,9	24,82	14,6
<b>Heating</b>																
Maximum working temperature	°C	100	100	100	100	100	100	100	100	100	100	100	100	100	100	100
Maximum working pressure in heating	bar	6	6	6	6	6	6	6	6	6	6	6	6	6	6	6
No. elements		8	9	9	10	10	11	11	12	12	14	14	16	16	18	18
Minimum working pressure in heating	bar	0,8	0,8	0,8	0,8	0,8	0,8	0,8	0,8	0,8	0,8	0,8	0,8	0,8	0,8	0,8
No. burner trains		7	8	8	9	9	10	10	11	11	13	13	15	15	17	17
Boiler water content	litres	38	42	42	46	46	50	50	54	54	62	62	70	70	78	78
<b>Dimensions, weights connections</b>																
Height	mm	1050	1050	1050	1050	1050	1050	1050	1050	1050	1050	1050	1050	1050	1050	1050
Width	mm	930	1020	1020	1100	1190	1190	1270	1270	1440	1440	1440	1610	1610	1780	1780
Depth	mm	1050	1050	1050	1050	1050	1050	1050	1050	1050	1050	1050	1100	1100	1100	1100
Weight with packing	kg	470	530	530	575	625	625	665	665	760	760	760	875	875	945	945
Gas system connection	inch.	1"	1"	1"	1" 1/2	1" 1/2	1" 1/2	1" 1/2	1" 1/2	1" 1/2	1" 1/2	1" 1/2	1" 1/2	1" 1/2	1" 1/2	1" 1/2
Heating system delivery	inch.	2"	2"	2"	2"	2"	2"	2"	2"	2"	2"	2"	2"	2"	2"	2"
Heating system return	inch.	2"	2"	2"	2"	2"	2"	2"	2"	2"	2"	2"	2"	2"	2"	2"
<b>Electrical power supply</b>																
Max electrical power absorbed	W	32	32	32	60	60	60	60	60	60	60	60	60	60	60	60
Power voltage/frequency	V/Hz	230/50	230/50	230/50	230/50	230/50	230/50	230/50	230/50	230/50	230/50	230/50	230/50	230/50	230/50	230/50
Electrical protection rating	IP	X0D	X0D	X0D	X0D	X0D	X0D	X0D	X0D	X0D	X0D	X0D	X0D	X0D	X0D	X0D

## 4.4 Diagrams

### Loss of head

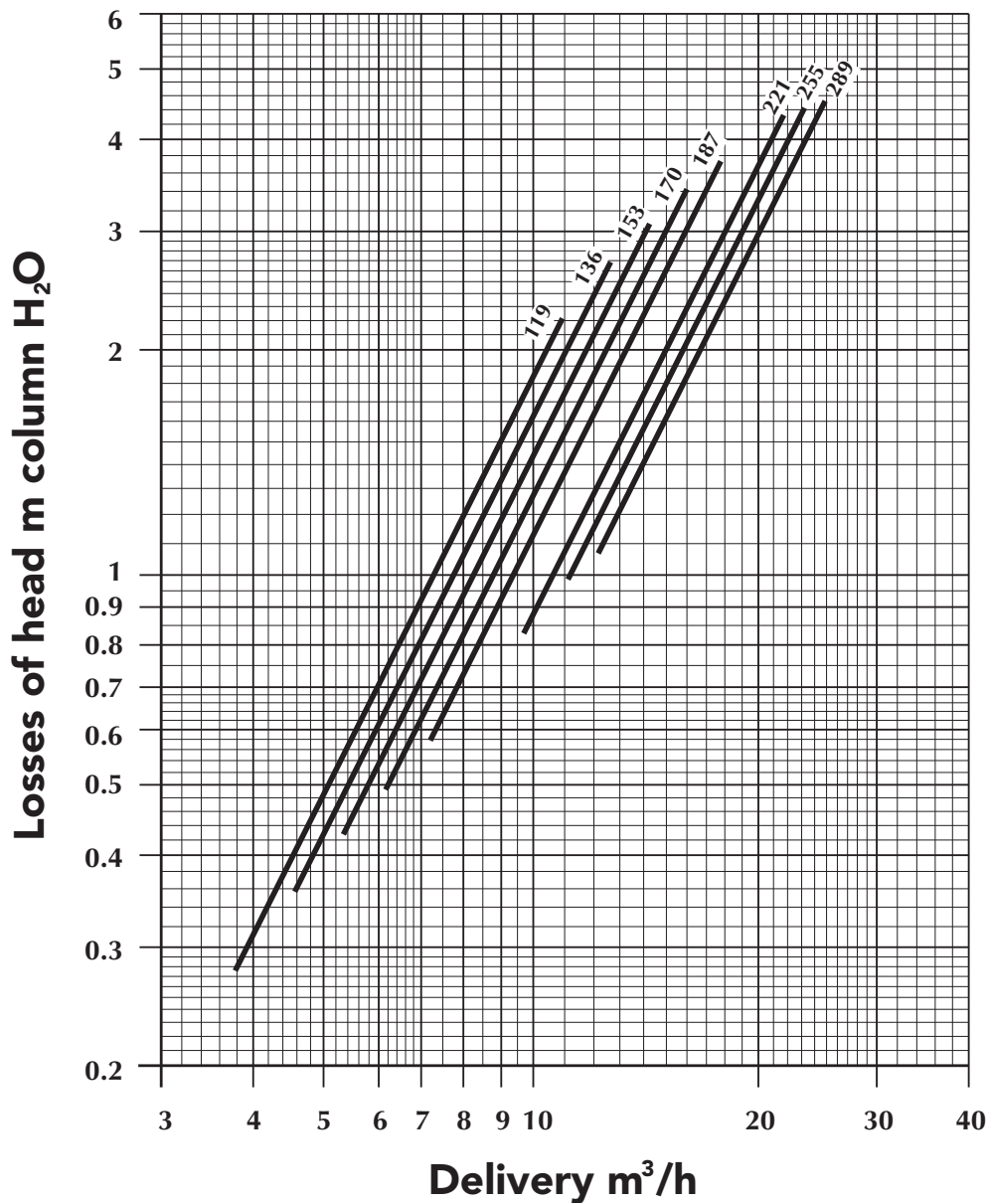

fig. 25

### 4.5 Wiring diagrams

#### Electrical connection diagram for 119 and 136 models

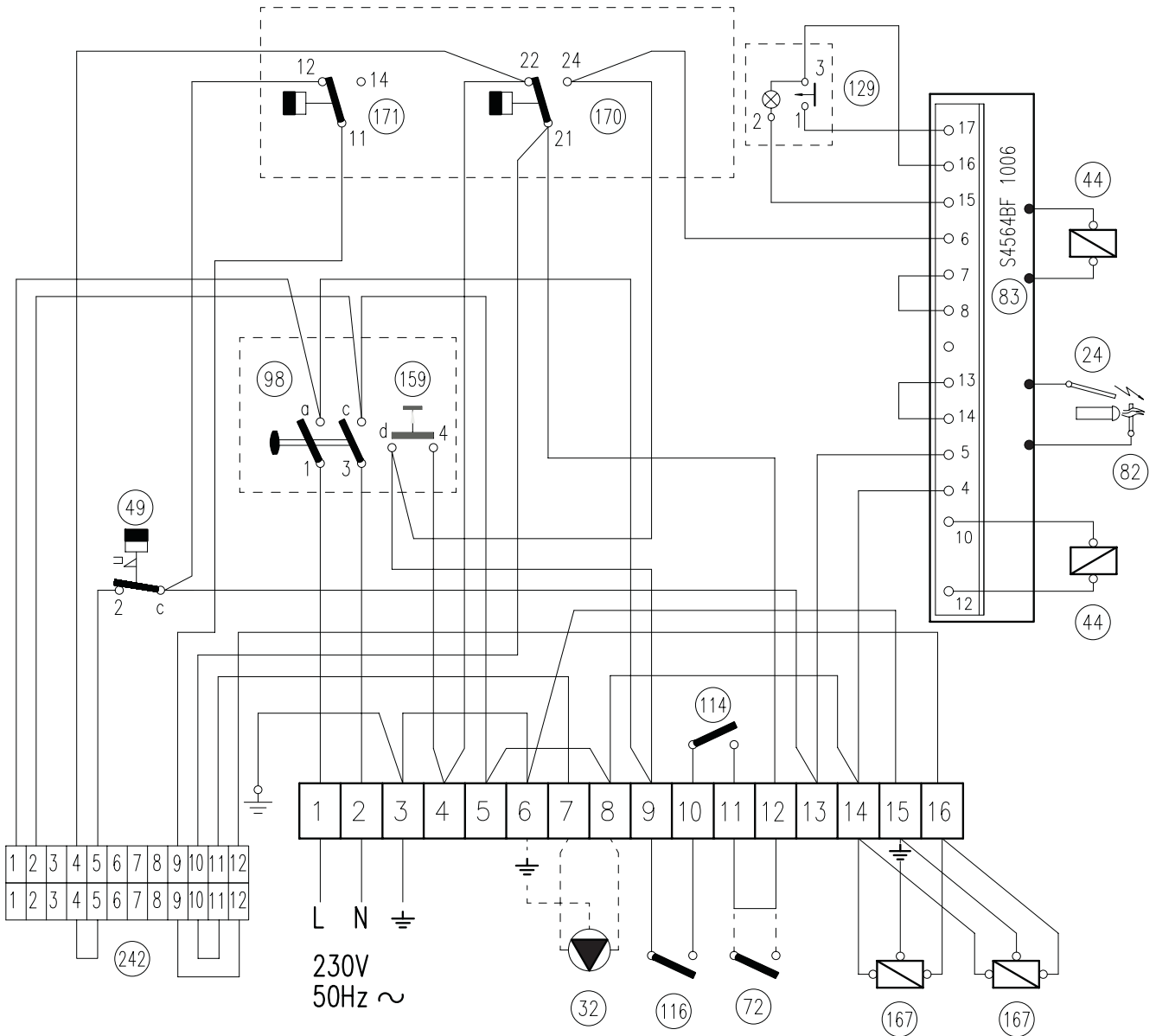

fig. 14a

**Key**

- |   |  |
|---|--|
| <b>24</b> Ignition electrode                | <b>114</b> Water pressure switch                 |
| <b>32</b> Heating circulator (not supplied) | <b>116</b> Gas pressure switch                   |
| <b>44</b> Gas valve                         | <b>129</b> Reset button with indicator lamp      |
| <b>49</b> Safety thermostat                 | <b>159</b> Test button                           |
| <b>72</b> Room thermostat (not supplied)    | <b>167</b> 2nd stage gas valve                   |
| <b>82</b> Detection electrode               | <b>170</b> 1st stage adjustment thermostat       |
| <b>83</b> Electronic controller             | <b>171</b> 2nd stage adjustment thermostat       |
| <b>98</b> Switch                            | <b>242</b> Connector for thermostatic controller |

Wiring laid out by the installer



## Main wiring diagram for 119 and 136 models

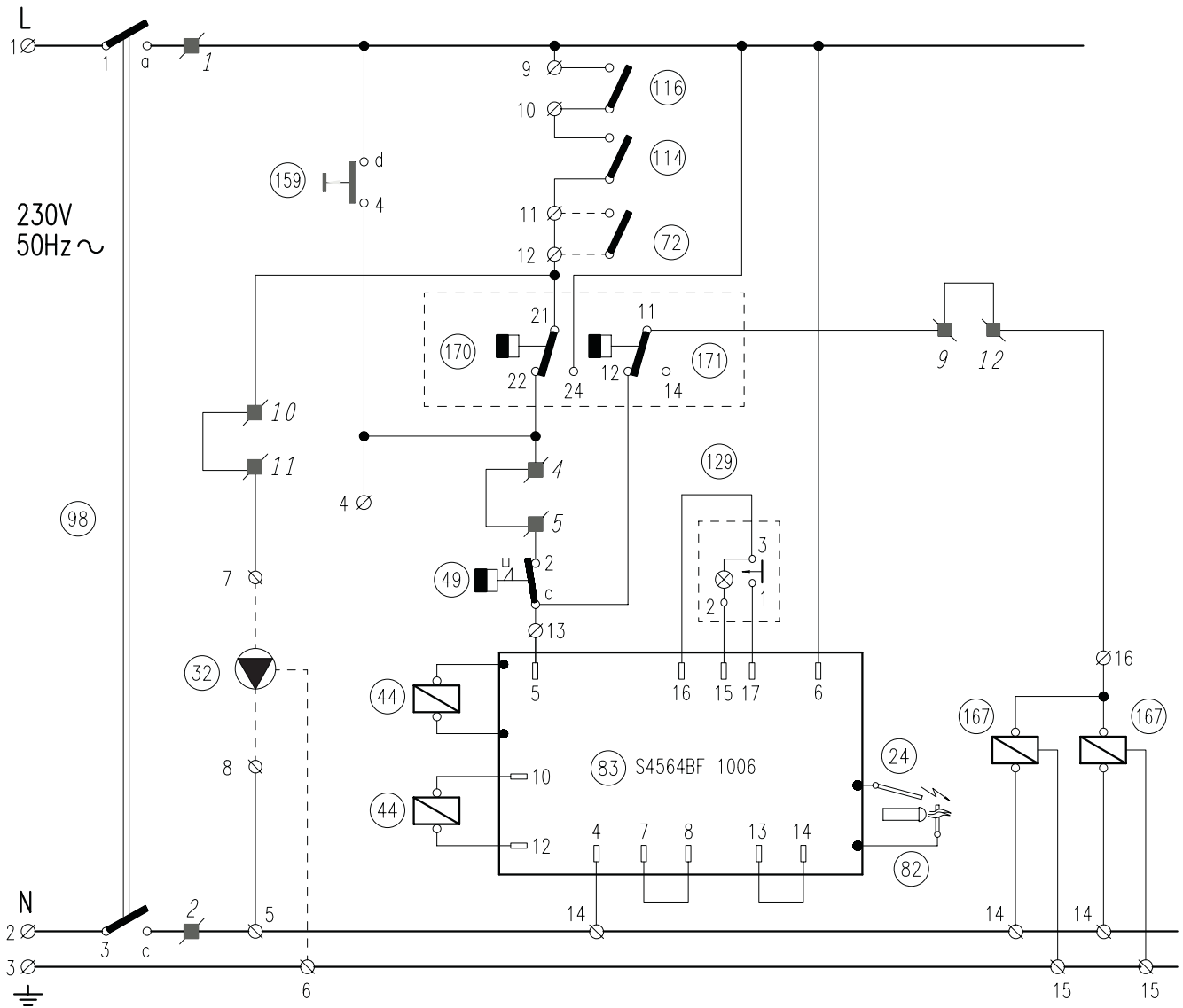

fig. 14b

### Key

- |   |  |
|---|--|
| <b>24</b> Ignition electrode                | <b>114</b> Water pressure switch                 |
| <b>32</b> Heating circulator (not supplied) | <b>116</b> Gas pressure switch                   |
| <b>44</b> Gas valve                         | <b>129</b> Reset button with indicator lamp      |
| <b>49</b> Safety thermostat                 | <b>159</b> Test button                           |
| <b>72</b> Room thermostat (not supplied)    | <b>167</b> 2nd stage gas valve                   |
| <b>82</b> Detection electrode               | <b>170</b> 1st stage adjustment thermostat       |
| <b>83</b> Electronic controller             | <b>171</b> 2nd stage adjustment thermostat       |
| <b>98</b> Switch                            | <b>242</b> Connector for thermostatic controller |

Wiring laid out by the installer

**Electrical connection diagram for 153, 170, 187, 221, 255 and 289 models**

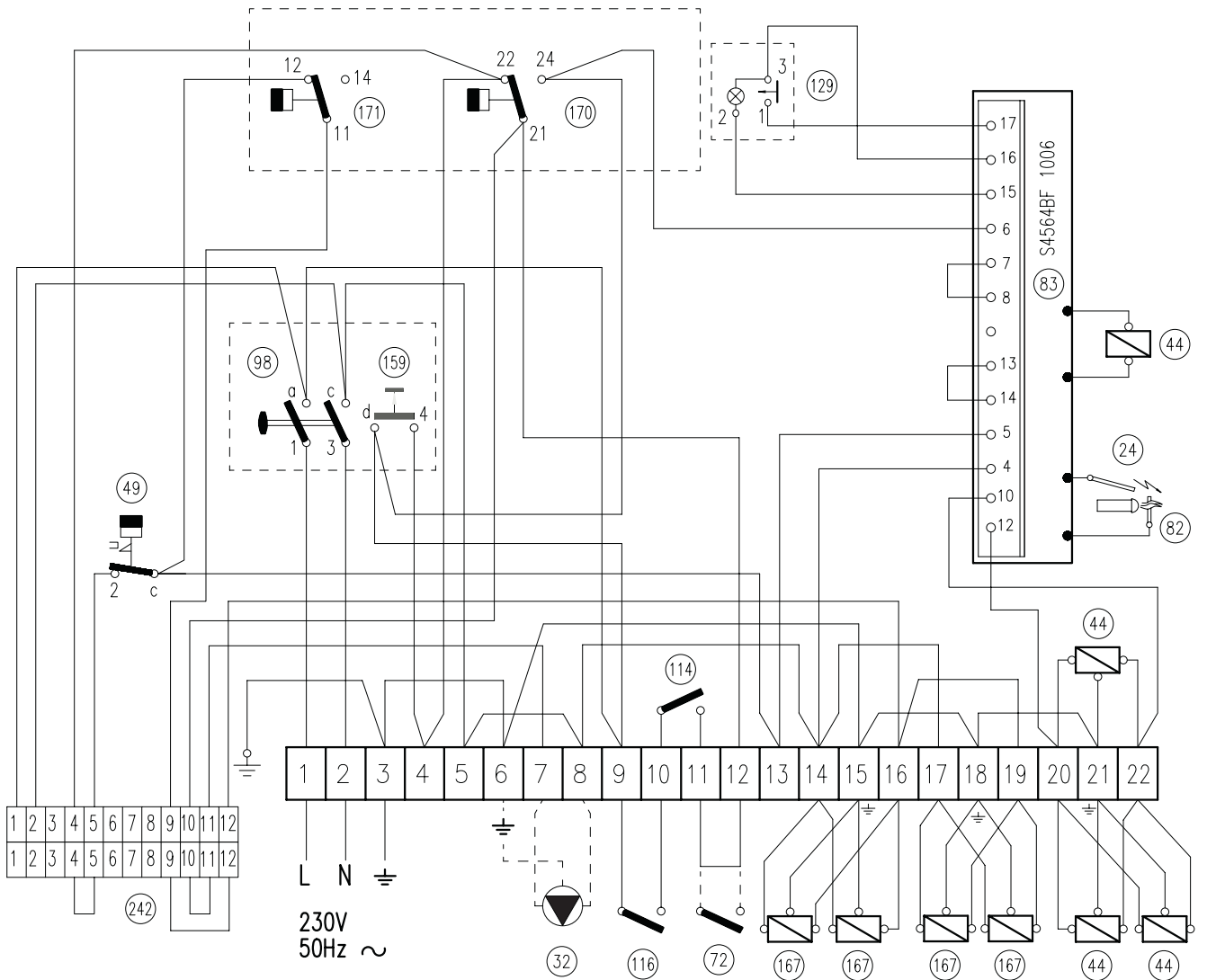

fig. 14c

**Key**

- |   |  |
|---|--|
| <b>24</b> Ignition electrode                | <b>114</b> Water pressure switch                 |
| <b>32</b> Heating circulator (not supplied) | <b>116</b> Gas pressure switch                   |
| <b>44</b> Gas valve                         | <b>129</b> Reset button with indicator lamp      |
| <b>49</b> Safety thermostat                 | <b>159</b> Test button                           |
| <b>72</b> Room thermostat (not supplied)    | <b>167</b> 2nd stage gas valve                   |
| <b>82</b> Detection electrode               | <b>170</b> 1st stage adjustment thermostat       |
| <b>83</b> Electronic controller             | <b>171</b> 2nd stage adjustment thermostat       |
| <b>98</b> Switch                            | <b>242</b> Connector for thermostatic controller |

## Main wiring diagram for 153, 170, 187, 221, 255 and 289 models

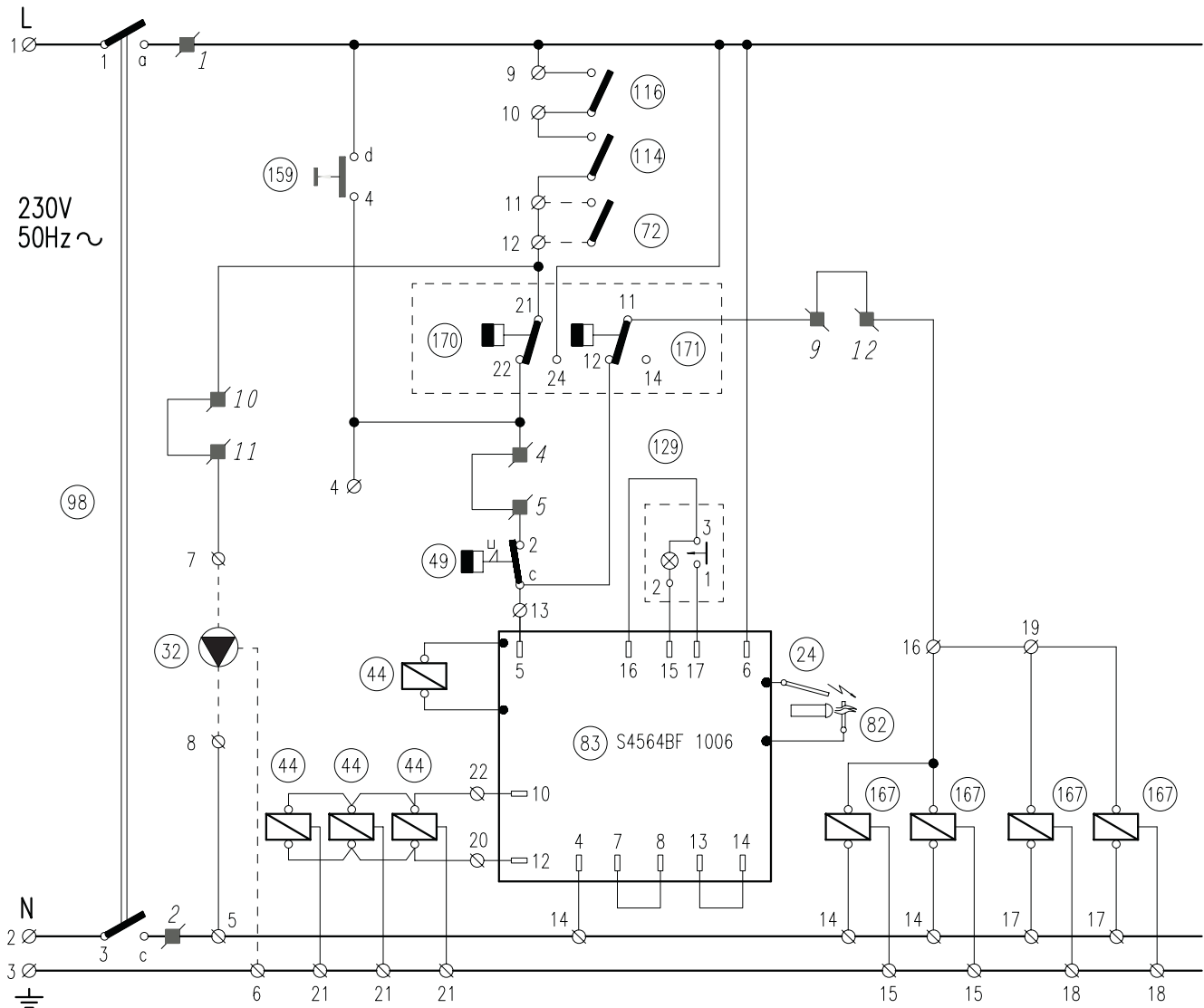

fig. 14d

### Key

- |           |                                   |            |                                       |
|-----------|-----------------------------------|------------|---------------------------------------|
| <b>24</b> | Ignition electrode                | <b>114</b> | Water pressure switch                 |
| <b>32</b> | Heating circulator (not supplied) | <b>116</b> | Gas pressure switch                   |
| <b>44</b> | Gas valve                         | <b>129</b> | Reset button with indicator lamp      |
| <b>49</b> | Safety thermostat                 | <b>159</b> | Test button                           |
| <b>72</b> | Room thermostat (not supplied)    | <b>167</b> | 2nd stage gas valve                   |
| <b>82</b> | Detection electrode               | <b>170</b> | 1st stage adjustment thermostat       |
| <b>83</b> | Electronic controller             | <b>171</b> | 2nd stage adjustment thermostat       |
| <b>98</b> | Switch                            | <b>242</b> | Connector for thermostatic controller |



BENCHMARK No. | 2 | 6 | 7 | | | |

Please add the first 4 digits of the Boiler serial No to complete the BENCHMARK No.

# GAS BOILER COMMISSIONING CHECKLIST

BOILER SERIAL No. \_\_\_\_\_ NOTIFICATION No. \_\_\_\_\_

**CONTROLS** To comply with the Building Regulations, each section must have a tick in one or other of the boxes

TIME & TEMPERATURE CONTROL TO HEATING	ROOM T/STAT & PROGRAMMER/TIMER <input type="checkbox"/>	PROGRAMMABLE ROOMSTAT <input type="checkbox"/>
TIME & TEMPERATURE CONTROL TO HOT WATER	CYLINDER T/STAT & PROGRAMMER/TIMER <input type="checkbox"/>	COMBI BOILER <input type="checkbox"/>
HEATING ZONE VALVES	FITTED <input type="checkbox"/>	NOT REQUIRED <input type="checkbox"/>
HOT WATER ZONE VALVES	FITTED <input type="checkbox"/>	NOT REQUIRED <input type="checkbox"/>
THERMOSTATIC RADIATOR VALVES	FITTED <input type="checkbox"/>	
AUTOMATIC BYPASS TO SYSTEM	FITTED <input type="checkbox"/>	NOT REQUIRED <input type="checkbox"/>

### FOR ALL BOILERS CONFIRM THE FOLLOWING

THE SYSTEM HAS BEEN FLUSHED IN ACCORDANCE WITH THE BOILER MANUFACTURER'S INSTRUCTIONS?

THE SYSTEM CLEANER USED \_\_\_\_\_

THE INHIBITOR USED \_\_\_\_\_

### FOR THE CENTRAL HEATING MODE, MEASURE & RECORD

GAS RATE \_\_\_\_\_ m<sup>3</sup>/hr \_\_\_\_\_ ft<sup>3</sup>/hr

BURNER OPERATING PRESSURE (IF APPLICABLE)  N/A \_\_\_\_\_ mbar

CENTRAL HEATING FLOW TEMPERATURE \_\_\_\_\_ °C

CENTRAL HEATING RETURN TEMPERATURE \_\_\_\_\_ °C

### FOR COMBINATION BOILERS ONLY

HAS A WATER SCALE REDUCER BEEN FITTED? YES  NO

WHAT TYPE OF SCALE REDUCER HAS BEEN FITTED? \_\_\_\_\_

### FOR THE DOMESTIC HOT WATER MODE, MEASURE & RECORD

GAS RATE \_\_\_\_\_ m<sup>3</sup>/hr \_\_\_\_\_ ft<sup>3</sup>/hr

MAXIMUM BURNER OPERATING PRESSURE (IF APPLICABLE)  N/A \_\_\_\_\_ mbar

COLD WATER INLET TEMPERATURE \_\_\_\_\_ °C

HOT WATER OUTLET TEMPERATURE \_\_\_\_\_ °C

WATER FLOW RATE \_\_\_\_\_ lts/min

### FOR CONDENSING BOILERS ONLY CONFIRM THE FOLLOWING

THE CONDENSATE DRAIN HAS BEEN INSTALLED IN ACCORDANCE WITH THE MANUFACTURER'S INSTRUCTIONS? YES

### FOR ALL INSTALLATIONS CONFIRM THE FOLLOWING

THE HEATING AND HOT WATER SYSTEM COMPLIES WITH CURRENT BUILDING REGULATIONS

THE APPLIANCE AND ASSOCIATED EQUIPMENT HAS BEEN INSTALLED AND COMMISSIONED IN ACCORDANCE WITH THE MANUFACTURER'S INSTRUCTIONS

IF REQUIRED BY THE MANUFACTURER, HAVE YOU RECORDED A CO/CO<sub>2</sub> RATIO READING? N/A  YES  CO/CO<sub>2</sub> RATIO \_\_\_\_\_

THE OPERATION OF THE APPLIANCE AND SYSTEM CONTROLS HAVE BEEN DEMONSTRATED TO THE CUSTOMER

THE MANUFACTURER'S LITERATURE HAS BEEN LEFT WITH THE CUSTOMER

COMMISSIONING ENG'S NAME PRINT \_\_\_\_\_ CORGI ID No. \_\_\_\_\_

SIGN \_\_\_\_\_ DATE \_\_\_\_\_

# SERVICE INTERVAL RECORD

It is recommended that your heating system is serviced regularly and that you complete the appropriate Service Interval Record Below.

**Service Provider.** Before completing the appropriate Service Interval Record below, please ensure you have carried out the service as described in the boiler manufacturer's instructions. Always use the manufacturer's specified spare part when replacing all controls

## SERVICE 1 DATE

ENGINEER NAME \_\_\_\_\_  
COMPANY NAME \_\_\_\_\_  
TEL No. \_\_\_\_\_  
CORGI ID CARD SERIAL No. \_\_\_\_\_  
COMMENTS \_\_\_\_\_  
SIGNATURE \_\_\_\_\_

## SERVICE 2 DATE

ENGINEER NAME \_\_\_\_\_  
COMPANY NAME \_\_\_\_\_  
TEL No. \_\_\_\_\_  
CORGI ID CARD SERIAL No. \_\_\_\_\_  
COMMENTS \_\_\_\_\_  
SIGNATURE \_\_\_\_\_

## SERVICE 3 DATE

ENGINEER NAME \_\_\_\_\_  
COMPANY NAME \_\_\_\_\_  
TEL No. \_\_\_\_\_  
CORGI ID CARD SERIAL No. \_\_\_\_\_  
COMMENTS \_\_\_\_\_  
SIGNATURE \_\_\_\_\_

## SERVICE 4 DATE

ENGINEER NAME \_\_\_\_\_  
COMPANY NAME \_\_\_\_\_  
TEL No. \_\_\_\_\_  
CORGI ID CARD SERIAL No. \_\_\_\_\_  
COMMENTS \_\_\_\_\_  
SIGNATURE \_\_\_\_\_

## SERVICE 5 DATE

ENGINEER NAME \_\_\_\_\_  
COMPANY NAME \_\_\_\_\_  
TEL No. \_\_\_\_\_  
CORGI ID CARD SERIAL No. \_\_\_\_\_  
COMMENTS \_\_\_\_\_  
SIGNATURE \_\_\_\_\_

## SERVICE 6 DATE

ENGINEER NAME \_\_\_\_\_  
COMPANY NAME \_\_\_\_\_  
TEL No. \_\_\_\_\_  
CORGI ID CARD SERIAL No. \_\_\_\_\_  
COMMENTS \_\_\_\_\_  
SIGNATURE \_\_\_\_\_

## SERVICE 7 DATE

ENGINEER NAME \_\_\_\_\_  
COMPANY NAME \_\_\_\_\_  
TEL No. \_\_\_\_\_  
CORGI ID CARD SERIAL No. \_\_\_\_\_  
COMMENTS \_\_\_\_\_  
SIGNATURE \_\_\_\_\_

## SERVICE 8 DATE

ENGINEER NAME \_\_\_\_\_  
COMPANY NAME \_\_\_\_\_  
TEL No. \_\_\_\_\_  
CORGI ID CARD SERIAL No. \_\_\_\_\_  
COMMENTS \_\_\_\_\_  
SIGNATURE \_\_\_\_\_

## SERVICE 9 DATE

ENGINEER NAME \_\_\_\_\_  
COMPANY NAME \_\_\_\_\_  
TEL No. \_\_\_\_\_  
CORGI ID CARD SERIAL No. \_\_\_\_\_  
COMMENTS \_\_\_\_\_  
SIGNATURE \_\_\_\_\_

## SERVICE 10 DATE

ENGINEER NAME \_\_\_\_\_  
COMPANY NAME \_\_\_\_\_  
TEL No. \_\_\_\_\_  
CORGI ID CARD SERIAL No. \_\_\_\_\_  
COMMENTS \_\_\_\_\_  
SIGNATURE \_\_\_\_\_







**Should you require help during installation  
call our Technical Helpline on  
08707 282 885 option 1  
To book a Ferroli service engineer  
call Ferroli caresafe on  
08707 282 885 option 2**

**Phone numbers:**

**Installer** \_\_\_\_\_

**Service Engineer** \_\_\_\_\_

**BECAUSE OF OUR CONSTANT ENDEAVOUR FOR IMPROVEMENT DETAILS  
MAY VARY SLIGHTLY FROM THOSE QUOTED IN THESE INSTRUCTIONS.**

---

**ALL SPECIFICATIONS SUBJECT TO CHANGE**

**Please note** - to avoid incurring unnecessary expense, in the event of a boiler shut down, check this is not caused by lack of electricity supply, gas supply or low water pressure before calling our Customer Service Helpline.

**Lichfield Road, Branston Industrial Estate, Burton Upon Trent, Staffordshire DE14 3HD  
Tel. 08707 282 885 - Fax 08707 282 886**