



TECHNICAL MANUAL

GB

WALL

TO BE ASSEMBLED ON-SITE

WALL M

COMPLETELY ASSEMBLED ON ITS BASE

**CONDENSING
LOW NO_x BOILER**

CE

INDICE

1	GENERAL	2
2	CERTIFICATION DATA	3
3	TECHNICAL DATA	4
4	INSTALLATION	6
4.1	THERMAL PLANT	6
4.1.1	BOILER ROOM.....	6
4.1.2	EXTERNAL INSTALLATION	6
4.2	CHIMNEY.....	6
4.3	HYDRAULIC CONNECTIONS.....	6
4.4	ELECTRICAL CONNECTIONS	7
4.5	MASTER CONTROL PANEL.....	7
4.6	WIRING DIAGRAM	7
4.7	MODULAR UNIT OPERATING PRINCIPLE	8
4.8	SLAVE CONTROL PANEL	8
4.9	CENTRAL MASTER CONTROL PANEL	8
4.9.1	MODULAR UNIT WIRING DIAGRAM	8
4.10	PREMIX BURNER.....	9
4.10.1	ASSEMBLY.....	9
4.11	BOILER SHELL ISOLATION.....	9
4.12	SINGLE GROUP PIPING INSTALLATION KIT.....	9
5	COVER ASSEMBLY	10
5.1	SINGLE GROUP COVER FRAME	10
5.2	SINGLE GROUP COVER PANELS.....	11
5.3	GROUP UNIT PREMIX BURNERS	12
5.4	BOILER SHELL ISOLATION	12
5.5	MODULE POSITIONING	12
5.6	MODULAR UNIT PIPING INSTALLATION KIT	13
6	MODULAR UNIT COVER ASSEMBLY	14
6.1	MODULAR UNIT FRAME COVER	14
6.2	MODULAR UNIT COVER PANELS.....	15
7	START UP	16
7.1	PRELIMINARY CHECKS	16
7.2	WATER TREATMENT	16
7.3	FILLING THE SYSTEM.....	16
8	OPERATION	17
8.1	IGNITION	17
9	OPERATION	18
9.1	OPERATION CHECKS	18
9.2	TEMPORARY BOILER STOP	18
9.3	PROLONGED BOILER STOP	18
9.4	PERIODICAL CHECKS	18
9.5	MAINTENANCE AND CLEANING.....	18

1 GENERAL

This is a commercial condensing boiler patented. The boiler condenses and utilises the latent heat absorbed from the flue gases

The boiler has no limit on boiler return temperature so the best boiler performance (efficiency 107,5%) is reached when the boiler is fitted to an under floor heating circuit or when the return temperature is under 58 deg. C . Above this temperature, the condensation phenomenon does not take place and so it is not possible take the latent heat from the vapour of the flue. The boiler efficiency is still very high (98,3%) even when the boiler is fitted in a traditional heating circuit plant working at Δt 80/60 deg. C.

The body that is slightly inclined, is composed of:

- wet through-flame furnace
- corrugated horizontal flue passages, whose special surface increases: the heat exchange area, the flue gas turbulence and the formation of condense, the easy drainage of same.
- boiler shell complete with boiler flow, constant temperature return , variable temperature return, fittings for control thermostats and safety devices.
- rear smoke box has the function to drain the condense and chimney connection to drain any condense from the chimney.

All the parts of the boiler are manufactured in stainless steel AISI 316 Ti.

The premix burner, the particular flame path (through the combustion chamber without inversion) and the high volume of the furnace limits as much as possible the formation of Nitrogen Oxides (NOx) that form when the flame remains at high temperature in the combustion chamber for long periods.

The high boiler efficiency is due to optimum combustion efficiency combined high density rock wool insulation, which puts the boiler in the top position in European regulation “4 stars” according the Efficiency Directive 92/42/EEC.

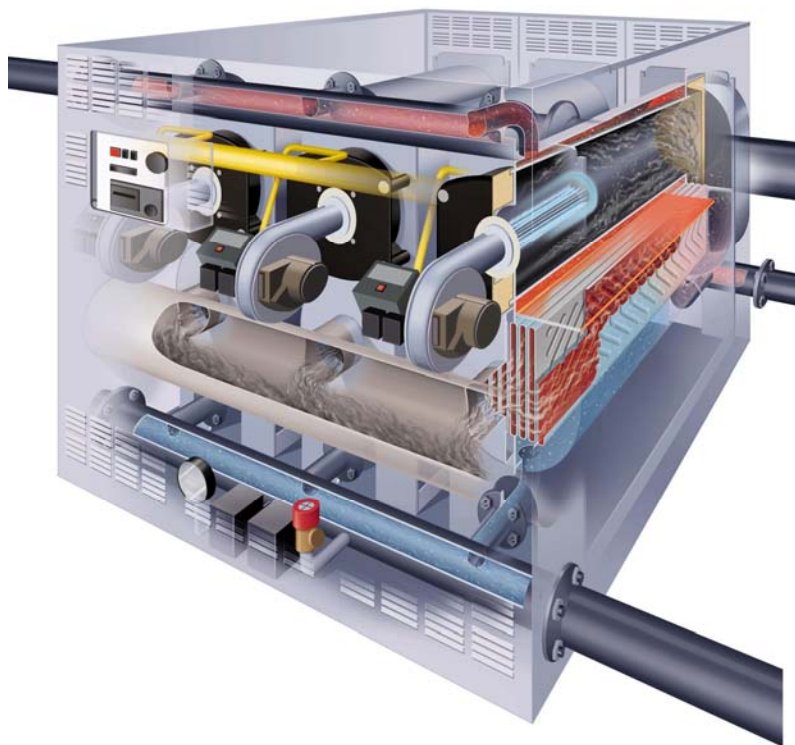

2 CERTIFICATION DATA

Each boiler is provided with a **manufacturer's plate** that can be found in the envelope with the boiler documents. The plate lists:

- Serial number or identification code
- Rated thermal output in kcal/h and in kW
- Furnace thermal output in kcal/h and in kW
- Types of fuels that can be used (natural gas or lpg)
- Max operating pressure.

A **manufacturer's certificate** is also provided which certifies the hydraulic test.

The installation must be in compliance with local regulations in force by **professionally qualified personnel**. The term "professionally qualified personnel" means persons with specific technical skills in the sector of heating system components.

Incorrect installation may cause damage to persons, animals or objects for which the manufacturer cannot be held responsible.

At the first start up, all regulation and control devices positioned on the control panel should be checked for efficiency. The **guarantee** shall be valid only upon compliance with the instruction given in this manual.

Our boilers have been built and tested in observance of EEC requirements and, as a consequence, CE-marked. EEC directives are as follows:

- **Directive on Gas** 90/396/EEC
- **Directive on Output** 92/42/EEC
- **Directive on Electromagnetic Compatibility** 89/336/EEC
- **Directive on Low Voltage** 73/23/EEC

IMPORTANT: This boiler has been designed to heat water to a temperature less than the boiling temperature of water at atmospheric pressure and must be connected to a heating plant and/or a domestic hot water plant within the limits of its performance and output.

WARNING!

THE BOILER MAY ONLY BE INSTALLED IN A ROOM WHICH COMPLIES WITH THE APPROPRIATE VENTILATION REQUIREMENTS. READ THE INSTALLATION AND USER INSTRUCTION BEFORE INSTALLING AND LIGHTING THE BOILER.



Systems must be cleaned in accordance with British Standard Code of Practice BS 7593:1992, Code of practice for treatment of water in central heating systems.

3 TECHNICAL DATA

Characteristics		Heat output				Furnace output		Efficiency 100% (N.C.V.)		Effic. 100% (stars)	NG max flow rate G20	NG max flow rate G30	NG max flow rate G31
		kW	kcal/h	kW	kcal/h	kW	kcal/h	%	%	%	m³/h	kg/h	kg/h
		Medium Temp. 70°C		Temp. flow/return 50/30°C				Medium Temp. 70°C	Temp. flow/return 50/30°C	(Efficiency Dir. 92/42/CEE)			
WALL 125	WALL 125 M	113,4	97.514	124	106.640	115,3	99.200	98,3	107,5	****	12,21	9,06	8,96
WALL 150	WALL 150 M	137,2	117.960	150	129.000	139,5	120.000	98,3	107,5	****	14,77	10,96	10,84
WALL 250	WALL 250 M	226,8	195.027	248	213.280	230,7	198.400	98,3	107,5	****	24,41	18,12	17,92
WALL 300	WALL 300 M	274,3	235.920	300	258.000	279,1	240.000	98,3	107,5	****	29,53	21,92	21,68
WALL 375	WALL 375 M	340,2	292.541	372	319.920	346,0	297.600	98,3	107,5	****	36,62	27,18	26,88
WALL 450	WALL 450 M	411,5	353.880	450	387.000	418,6	360.000	98,3	107,5	-	44,30	32,88	32,52
WALL 500	WALL 500 M	453,6	390.054	496	426.560	461,4	396.800	98,3	107,5	-	48,82	36,24	35,84
WALL 600	WALL 600 M	548,7	471.840	600	516.000	558,1	480.000	98,3	107,5	-	59,06	43,84	43,36

Characteristics		Minimum output				Minimum input		Efficiency at 30% (N.C.V.)		Effic. 30% (stars)	NG min flow rate G20	NG min flow rate G30	NG min flow rate G31
		kW	kcal/h	kW	kcal/h	kW	kcal/h	%	%	%	m³/h	kg/h	kg/h
		Medium Temp. 70°C		Temp. flow/return 50/30°C				Medium Temp. 70°C	Temp. flow/return 50/30°C	(Efficiency Dir. 92/42/CEE)			
WALL 125	WALL 125 M	18,9	16.254	20,9	17.974	19,2	16.512	98,5	109	****	2,03	1,51	1,49
WALL 150	WALL 150 M	23,0	19.780	25,4	21.844	23,3	20.038	98,5	109	****	2,47	1,83	1,81
WALL 250	WALL 250 M	37,9	32.594	42,0	36.120	38,5	33.110	98,5	109	****	4,07	3,02	2,99
WALL 300	WALL 300 M	45,8	39.388	50,7	43.602	46,5	39.990	98,5	109	****	4,92	3,65	3,61
WALL 375	WALL 375 M	56,8	48.848	62,9	54.094	57,7	49.622	98,5	109	****	6,11	4,53	4,48
WALL 450	WALL 450 M	68,8	59.168	76,1	65.446	69,8	60.028	98,5	109	-	7,39	5,48	5,42
WALL 500	WALL 500 M	75,7	65.102	83,8	72.068	76,9	66.134	98,5	109	-	8,14	6,04	5,97
WALL 600	WALL 600 M	91,6	78.776	101,4	87.204	93,0	79.980	98,5	109	-	9,84	7,30	7,22

Characteristics	Pressure losses flue gas side mbar	Chimney available head mbar	Noise level dB(A)	CO emissions mg/kWh	Nox emissions mg/kWh	NOx class	Heat losses through the chimney			Heat losses through the casing			Heat losses with burner off			Flue gas temp. at boiler output and air at 20 deg. C		Condense production kg/h	Press. losses water side mbar	Design Pressure bar	Total capacity l	Boiler weight kg	Electric supply Volt ~	Frequency Hz	Insulation class IP	Electric power W	Fuel	
							%	%	%	%	%	%	%	°C	°C	Temp. flow/return 50/30°C	(ΔT=12°C)										Nat. gas	Lpg
							For condensing Temp. flow/return 50/30°C	For condensing Temp. flow/return 50/30°C	For condensing Temp. flow/return 50/30°C	For condensing Temp. flow/return 50/30°C	For condensing Temp. flow/return 50/30°C	For condensing Temp. flow/return 50/30°C	For condensing Temp. flow/return 50/30°C	GAS For condensing Temp. flow/return 50/30°C	Temp. flow/return 50/30°C													
WALL 125	2,4	0,5	62	0	40	5	1,50	0,30	0,10	40	14,47	20	4	220	250	230	50	IP 44	200	X	X							
WALL 150	3,4	0,5	65	0	40	5	1,50	0,30	0,10	40	17,50	20	4	220	250	230	50	IP 44	200	X	X							
WALL 250	2,4	0,5	65	0	40	5	1,50	0,30	0,10	40	28,93	20	4	440	500	230	50	IP 44	400	X	X							
WALL 300	3,4	0,5	68	0	40	5	1,50	0,30	0,10	40	34,99	20	4	440	500	230	50	IP 44	400	X	X							
WALL 375	2,4	0,5	68	0	40	5	1,50	0,30	0,10	40	43,39	20	4	660	750	230	50	IP 44	600	X	X							
WALL 450	3,4	0,5	70	0	40	5	1,50	0,30	0,10	40	52,50	20	4	660	750	230	50	IP 44	600	X	X							
WALL 500	2,4	0,5	70	0	40	5	1,50	0,30	0,10	40	57,85	20	4	880	1000	230	50	IP 44	800	X	X							
WALL 600	3,4	0,5	71	0	40	5	1,50	0,30	0,10	40	69,99	20	4	880	1000	230	50	IP 44	800	X	X							
WALL 125 M	2,4	0,5	62	0	40	5	1,50	0,30	0,10	40	14,47	20	4	220	335	230	50	IP 44	200	X	X							
WALL 150 M	3,4	0,5	65	0	40	5	1,50	0,30	0,10	40	17,50	20	4	220	335	230	50	IP 44	200	X	X							
WALL 250 M	2,4	0,5	65	0	40	5	1,50	0,30	0,10	40	28,93	20	4	440	660	230	50	IP 44	400	X	X							
WALL 300 M	3,4	0,5	68	0	40	5	1,50	0,30	0,10	40	34,99	20	4	440	660	230	50	IP 44	400	X	X							
WALL 375 M	2,4	0,5	68	0	40	5	1,50	0,30	0,10	40	43,39	20	4	660	985	230	50	IP 44	600	X	X							
WALL 450 M	3,4	0,5	70	0	40	5	1,50	0,30	0,10	40	52,50	20	4	660	985	230	50	IP 44	600	X	X							
WALL 500 M	2,4	0,5	70	0	40	5	1,50	0,30	0,10	40	57,85	20	4	880	1300	230	50	IP 44	800	X	X							
WALL 600 M	3,4	0,5	71	0	40	5	1,50	0,30	0,10	40	69,99	20	4	880	1300	230	50	IP 44	800	X	X							

Pressure losses water side

Δp (mbar)

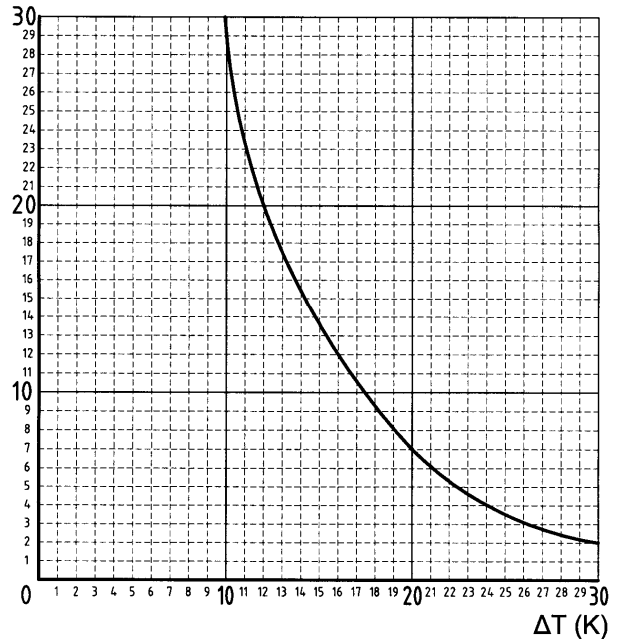

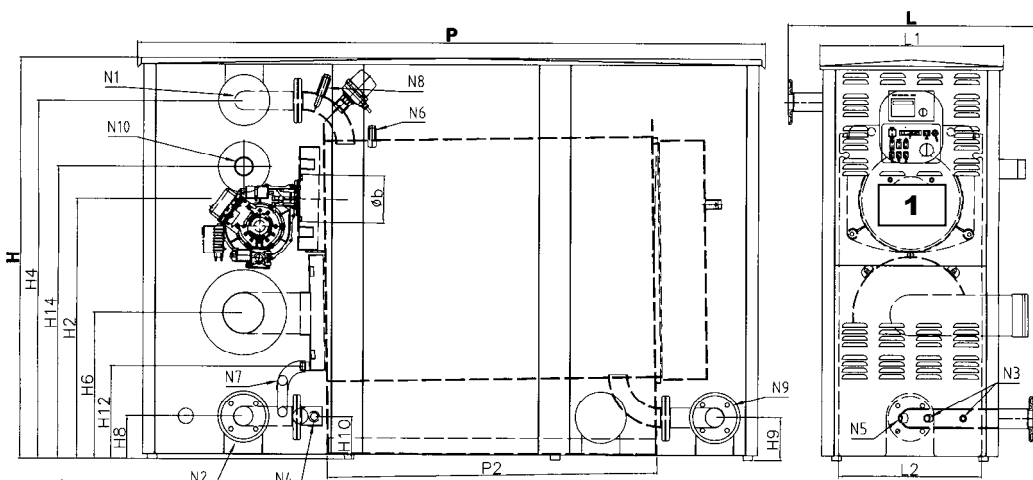

**WALL
WALL M
125-150**

- FITTINGS**
 N1 Boiler flow
 N2 Medium temperature return
 N3 Fitting for Instruments
 N4 System drainage
 N5 Safety valve fitting
 N6 Bulbs wells
 N7 Boiler condensation drain
 N8 Inspection well
 N9 Low temperature return
 N10 Gas fitting

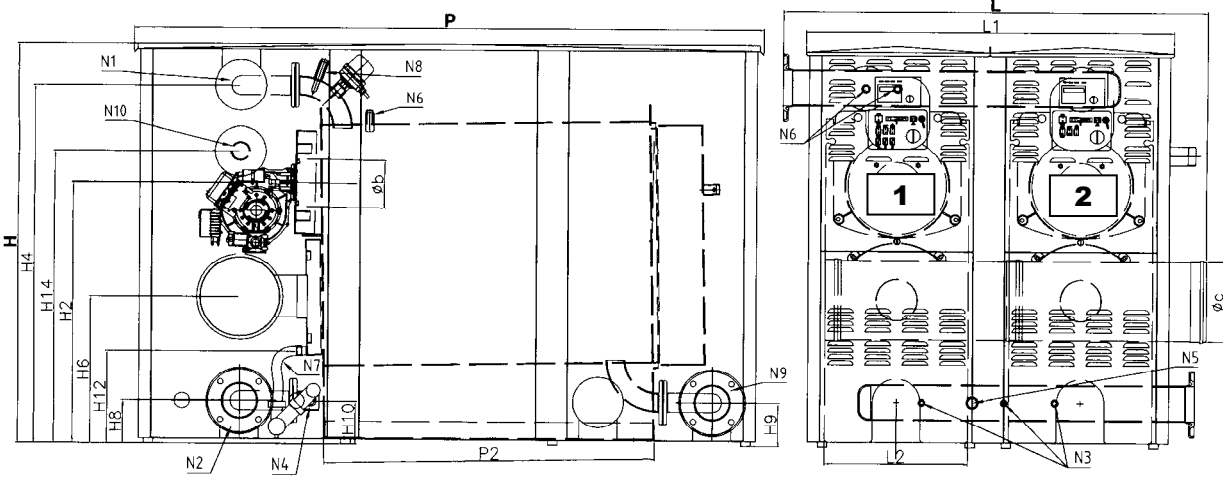

**WALL
WALL M
250-300**

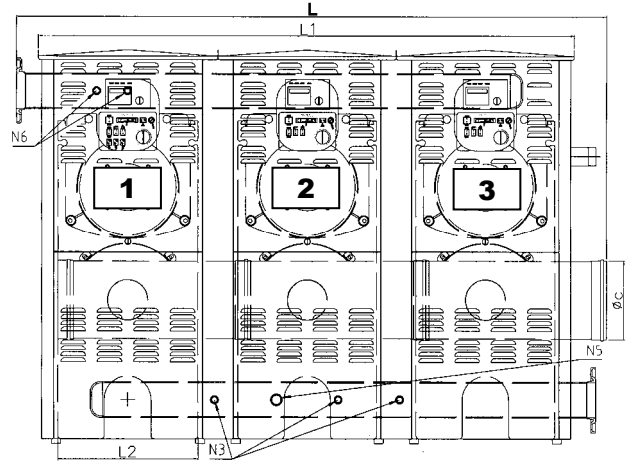

WALL/WALL M 375-450

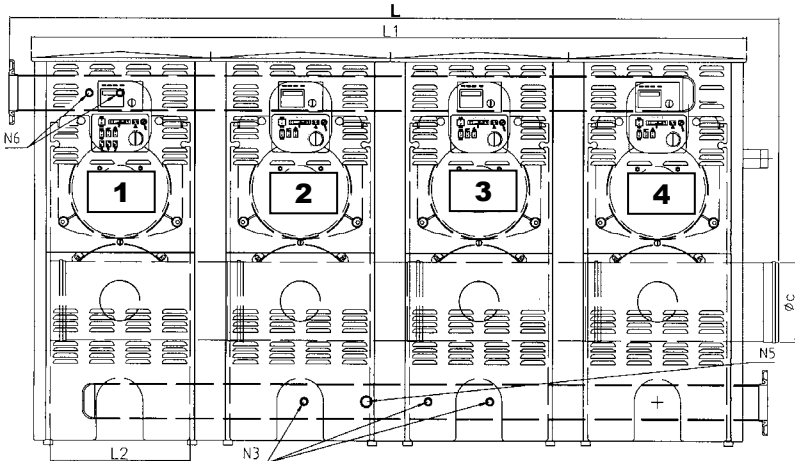

WALL/WALL M 500-600

Dimensions	H	H2	H4	H6	H8	H9	H10	H12	H14	L	L1	L2	P	P2	Øb	Øc	N1	N2	N3	N4	N5	N6	N7	N8	N9	N10
mm	mm	mm	mm	mm	mm	mm	mm	mm	mm	mm	mm	mm	mm	mm	mm	mm	DN/in	DN/in	DN/in	DN/in	in	in	in	in	DN/in	DN/in
WALL 125	1265	820	1130	455	130	130	130	285	920	795	578	450	1975	1038	150	125	50	50	1/4"-3/8"	3/4"	1/2"	1/2"	3/4"	1/2"	50	25
WALL 150	1265	820	1130	455	130	130	130	285	920	795	578	450	1975	1038	150	125	50	50	1/4"-3/8"	3/4"	1/2"	1/2"	3/4"	1/2"	50	25
WALL 250	1265	820	1130	455	130	130	130	285	920	1368	1155	450	1975	1038	150	250	100	100	1/4"-3/8"	3/4"	1"	1/2"	3/4"	1/2"	100	50
WALL 300	1265	820	1130	455	130	130	130	285	920	1368	1155	450	1975	1038	150	250	100	100	1/4"-3/8"	3/4"	1"	1/2"	3/4"	1/2"	100	50
WALL 375	1265	820	1130	455	130	130	130	285	920	1946	1733	450	1975	1038	150	250	100	100	1/4"-3/8"	3/4"	1"	1/2"	3/4"	1/2"	100	50
WALL 450	1265	820	1130	455	130	130	130	285	920	1946	1733	450	1975	1038	150	250	100	100	1/4"-3/8"	3/4"	1"	1/2"	3/4"	1/2"	100	50
WALL 500	1265	820	1130	455	130	130	130	285	920	2523	2310	450	1975	1038	150	250	100	100	1/4"-3/8"	3/4"	1"	1/2"	3/4"	1/2"	100	50
WALL 600	1265	820	1130	455	130	130	130	285	920	2523	2310	450	1975	1038	150	250	100	100	1/4"-3/8"	3/4"	1"	1/2"	3/4"	1/2"	100	50
WALL 125 M	1335	890	1200	525	200	200	200	355	990	795	578	450	1975	1038	150	125	50	50	1/4"-3/8"	3/4"	1/2"	1/2"	3/4"	1/2"	50	25
WALL 150 M	1335	890	1200	525	200	200	200	355	990	795	578	450	1975	1038	150	125	50	50	1/4"-3/8"	3/4"	1/2"	1/2"	3/4"	1/2"	50	25
WALL 250 M	1335	890	1200	525	200	200	200	355	990	1368	1155	450	1975	1038	150	250	100	100	1/4"-3/8"	3/4"	1"	1/2"	3/4"	1/2"	100	50
WALL 300 M	1335	890	1200	525	200	200	200	355	990	1368	1155	450	1975	1038	150	250	100	100	1/4"-3/8"	3/4"	1"	1/2"	3/4"	1/2"	100	50
WALL 375 M	1335	890	1200	525	200	200	200	355	990	1946	1733	450	1975	1038	150	250	100	100	1/4"-3/8"	3/4"	1"	1/2"	3/4"	1/2"	100	50
WALL 450 M	1335	890	1200	525	200	200	200	355	990	1946	1733	450	1975	1038	150	250	100	100	1/4"-3/8"	3/4"	1"	1/2"	3/4"	1/2"	100	50
WALL 500 M	1335	890	1200	525	200	200	200	355	990	2523	2310	450	1975	1038	150	250	100	100	1/4"-3/8"	3/4"	1"	1/2"	3/4"	1/2"	100	50
WALL 600 M	1335	890	1200	525	200	200	200	355	990	2523	2310	450	1975	1038	150	250	100	100	1/4"-3/8"	3/4"	1"	1/2"	3/4"	1/2"	100	50

4 INSTALLATION

Before **connecting** the boiler, the following operations must be completed:

- Thoroughly clean all the **system pipes** in order to remove any foreign matter that could affect correct operation of the boiler;
- Check that the **flue** has an **adequate draught**, that there is no narrowing of passages and that it is free from debris; also check that other appliances do not release into the flue (unless designed to serve several utilities). See the regulations in force.

4.1 THERMAL PLANT

4.1.1 BOILER ROOM

As a rule, regulations in force should be always observed. Premises in which boilers will be installed should be sufficiently ventilated and guarantee access for ordinary and extraordinary maintenance operations.

4.1.2 EXTERNAL INSTALLATION

It is possible to utilise a special base (optional) for external installation to further weatherproof the thermal plant.

4.2 CHIMNEY

The pressurised boiler, is so-called, because it uses a burner provided with fan. The fan introduces into the combustion chamber, the exact amount of air necessary in relation to the fuel and maintains an pressurisation in the furnace equivalent to all the internal resistances of the flue gas path as far as the boiler exhaust. At this point the fan pressure should have dropped to zero to prevent the flue connection pipe and the lower area of the flue itself from being under pressure and combustion gas leaks occurring in the boiler room.

The **connection pipe** from the boiler to the flue must slope incline in the direction of the flue gas flow with recommended gradient of no less than 10%. Its path must be as short and straight as possible with the bends and fittings rationally designed in accordance with air duct criteria

WARNING

The flue gas temperature of this boiler (between 35° and 100°C) is very low compare to the traditional non-condensing boilers, therefore, there is a very high humidity density. For this reason the boiler chimney must be water resistant, acid condense resistant and insulated to warrant sufficient draught.

4.3 HYDRAULIC CONNECTIONS

Ensure that the hydraulic pressure measured after the reduction valve on the supply pipe does not exceed the operating **pressure specified on the rating plate of the component** (boiler, heater etc.).

- As the water contained in the heating system increases in pressure during operation, ensure that its maximum value does not exceed the maximum hydraulic pressure specified on the component rating plate (5 bar).
- Ensure that the safety valve outlets of the boiler and hot water tank, if any, have been connected to drain in order to prevent the valves from **flooding the room** if they open.
- Ensure that the pipes of the water and heating system **are not used as an earth connection** for the electrical system as this can seriously and very rapidly damage the pipes, boiler, heater and radiators.
- Once the heating system has been filled, you are advised to close the supply cock and keep it closed so that **any leaks from the system** will be identified by a drop in hydraulic pressure indicated on the system pressure gauge.

IMPORTANT!

If the single boiler is not provided with acid condense neutralizer, a siphon must be fitted on the condensate drain in order to avoid flue gas leakage.

NOTE: IF ONLY ONE RETURN IS REQUIRED, ALWAYS USE THE LOW TEMPERATURE ONE

4.4 ELECTRICAL CONNECTIONS

Electrical systems of thermal plants designed only for heating purposes **must comply with numerous legal regulations which apply to in general as well as specifically to each application or fuel type.**

4.5 MASTER CONTROL PANEL (Fig. 1)

To be assembled on a single assembly system as the master of modular units coupled with slave panels.

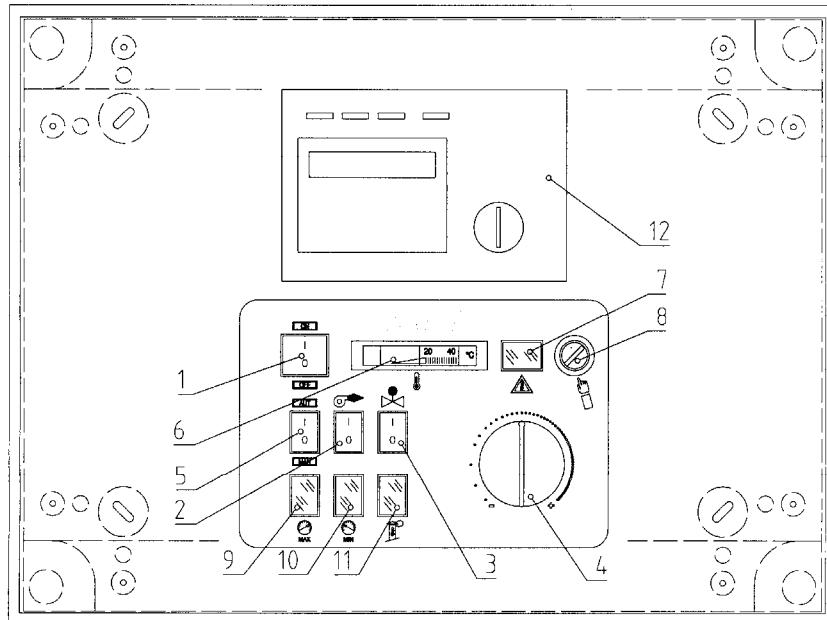

Fig. 1

LEGEND

- 1 MASTER SWITCH/ NETWORK INDICATOR
- 2 BURNER SWITCH
- 3 MOTORIZED RELEASE VALVE INDICATOR
(With selector 5 in AUT) 1=active valve 0=valve always closed
(With selector 5 in MAN) 1=valve always open 0=valve always closed
- 4 BITHERMOSTAT SETTING 1a-2a FLAME
- 5 MAN/AUT SELECTOR
- 6 BOILER THERMOMETER
- 7 THERMOSTAT BLOCK SAFETY INDICATOR
- 8 SAFETY THERMOSTAT
- 9 MAX PRESSURE REGULATOR INTERVENTION INDICATOR
- 10 MIN PRESSURE REGULATOR INTERVENTION INDICATOR
- 11 FLUE PRESSURE REGULATOR INTERVENTION INDICATOR
- 12 RVA 63 SWITCHBOARD

4.6 WIRING DIAGRAM

(Refer to the diagram provided)

4.7 MODULAR UNIT OPERATING PRINCIPLE

The group can be made up of two/three/four flanked units having power equal to which conduction is located in the single command panels run by a master panel. Each unit can operate autonomously, allowing partial generator operation. Released water temperature derives from the mixing of many equal flows, resulting equal to the medium of the release temperature of the single modules.

4.8 SLAVE CONTROL PANEL (Fig. 2)

Assembled on modular units coupled in tandem to a master panel.

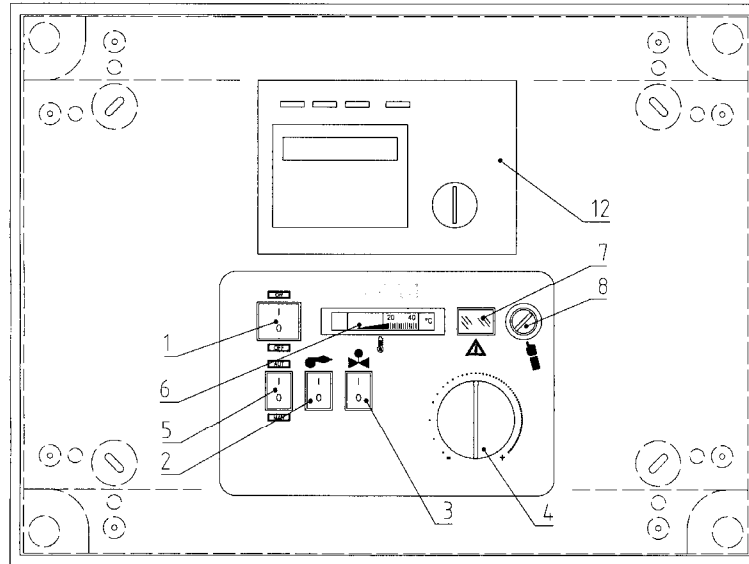

Fig. 2

LEGENDA

- 1 MASTER SWITCH/ NETWORK INDICATOR
- 2 BURNER SWITCH
- 3 MOTORIZED RELEASE VALVE INDICATOR
(With selector 6 in AUT) 1=active valve 0=valve always closed
(With selector 6 in MAN) 1=valve always open 0=valve always closed
- 4 BITHERMOSTAT SETTING 1a-2a FLAME
- 5 MAN/AUT SELECTOR
- 6 BOILER THERMOMETER
- 7 THERMOSTAT BLOCK SAFETY INDICATOR
- 8 SAFETY THERMOSTAT
- 12 RVA 63 SWITCHBOARD

4.9 CENTRAL MASTER CONTROL PANEL (Fig. 3)

An optional component to be assembled as a central master for managing all modular units.

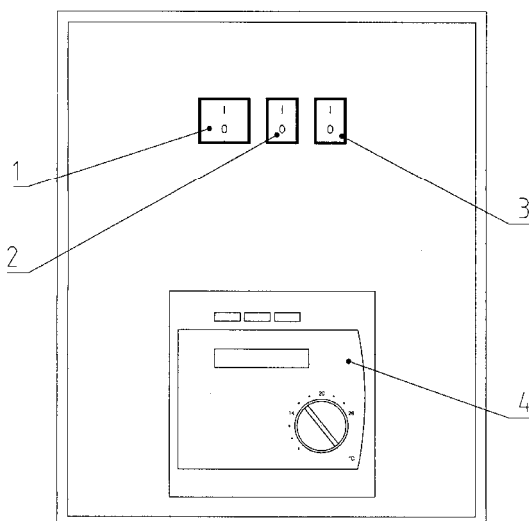

Fig. 3

LEGEND

- 1 MASTER SWITCH/NETWORK INDICATOR
- 2 SYSTEM CIRCULATOR SWITCH
- 3 BOILER CIRCULATOR SWITCH
- 4 RVA 43 SWITCHBOARD

4.9.1 MODULAR UNIT WIRING DIAGRAM

(See kit diagram)

4.10 PREMIX BURNER

4.10.1 ASSEMBLY

The premixed burner which equips the boiler is provided separately in an appropriately calibrated box. For assembly:

1. Apply boiler burner and secure it with the provided screws.
2. Connect the cable plugs which come out of the burner control panel.
3. Follow the control parameters for combustion (CO and CO₂).

Consult the attached equipment manual for burner instructions.

4.11 BOILER SHELL ISOLATION

- Wrap the glass wool around the boiler shell, adapting it to the top parts in correspondence to the sockets and then securing the bottom part with the appropriate grips.

4.12 SINGLE GROUP PIPING INSTALLATION KIT (Fig. 4)

1. Set the output side (dx or sx) of the piping.
2. Mount the piping with the relative gaskets and secure it with the provided screws:
 - System release DN 50 (1)
 - Low-temperature return system DN 50 (2)
 - Medium-temperature return system DN 50 (3)

NOTE: IF ONLY ONE RETURN IS REQUIRED, ALWAYS USE THE LOW TEMPERATURE ONE (2)

- Gas input DN 50 att. 3/4" (4)

ATTENTION: THE GAS PIPE MUST BE MOUNTED IN THE SAME DIRECTION AS THE RELEASE.

- Condensation release 3/4" (5)
- Flue system Ø 125 (6)

3. Assemble the safety accessories on the piping low-temperature return system (2): the safety valve (7), maximum and minimum pressure regulators (8), water flow switch (9) and gauge (10).
4. Insert the rubber holding washers (11) into the release/return gas piping.
5. Verify that the boiler is perfectly level, noting the bars (12) and plates (13) to guarantee a proper condensation drainage.

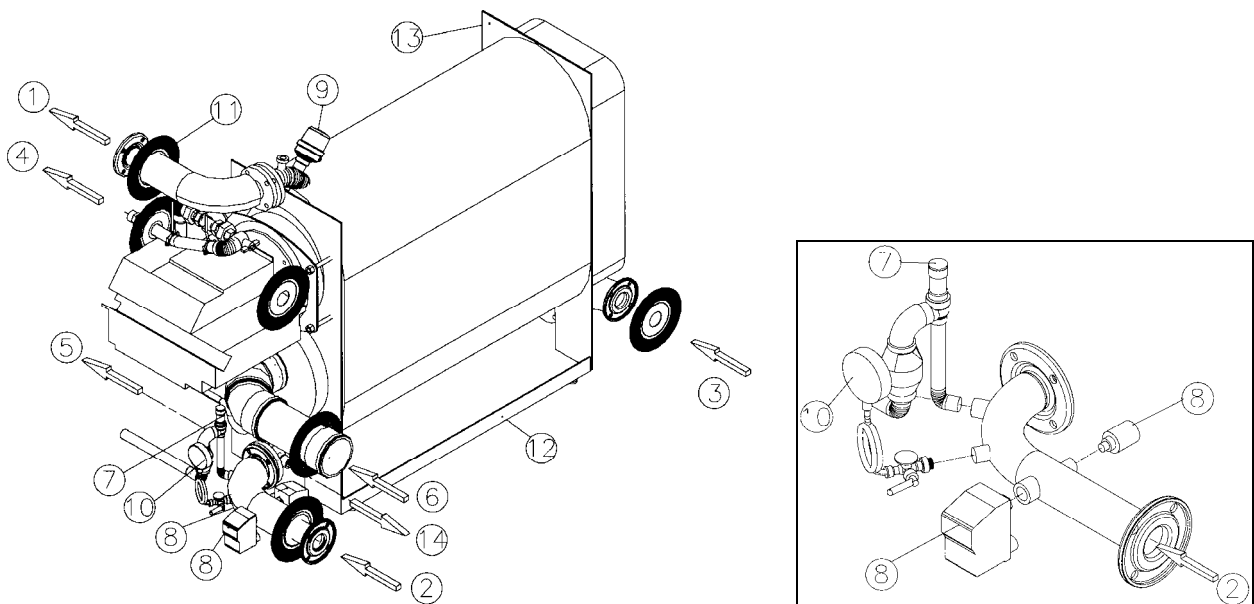

Fig. 4

LEGEND

- | | |
|---|---|
| 1. System release DN 50 | 8. Minimum and maximum pressure regulators 1/4" |
| 2. Low-temperature return system DN 50 | 9. Water flow switch 1" |
| 3. Medium-temperature return system DN 50 | 10. Gauge 3/8" |
| 4. Gas input DN 50 att. 3/4" | 11. Holding washers |
| 5. Condensation release 3/4" | 12. Bars |
| 6. Flue system Ø 125 | 13. Boiler plates |
| 7. Safety valve 1/2" | 14. Boiler flue 3/4" |

5 COVER ASSEMBLY

5.1 SINGLE GROUP COVER FRAME (Fig. 5)

1. Assemble the dx and sx sides, securing the bars (1) with the mounts (2 and 3) utilising the provided M4 screws.
2. Screw the adjustable feet (4) on the lower bars.
3. Lean the sides of the boiler.
4. Fasten the cross-bars (5) to the bars (1) as illustrated in the diagram and secure them with the appropriate screws.
5. Mount the control panel (6) to the front beam (5) and fix it to the mounts with the screws.
6. Insert the bulbs in the appropriate holes on the shell (thermostat adjustment 1st and 2nd flame, safety thermostat, boiler thermometer, electric switchboard probe).

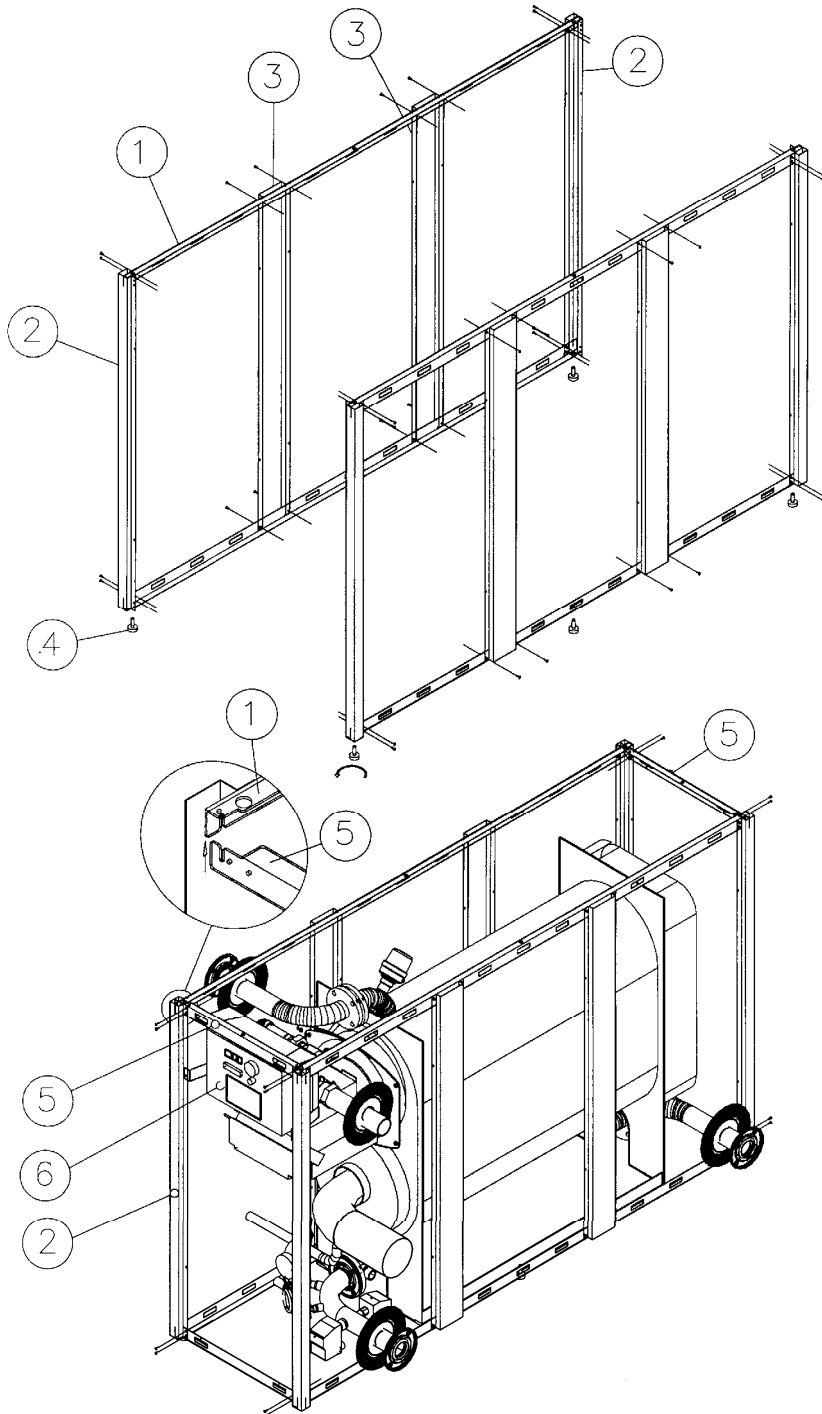

LEGEND

1. Bars
2. Front/back mounts
3. Side mounts
4. Adjustable feet
5. Cross-bars
6. Control panel

Fig. 5

5.2 SINGLE GROUP COVER PANELS (Fig. 6)

1. Remove the pre-cut pieces only in correspondence to the piping as illustrated (part A).
Note: for DN125 flue output, only cut internal ones.
2. Fasten the sides (1) and secure them with screws and nuts (4-13) to the mounts.
3. Fasten the sides (2-5-6), adapt the gaskets (part B), secure the pipes for the buttonhole (3-7) with the attached 2-sided adhesive and close the holes with a fairlead (14). There are 2 holes for fastening the frame to the ground on the front/back of the sides of the frame.
4. Fasten the back panel (8) to the lower door (9) and secure it with screws (4) and nuts (13) to the mounts, the opening door (10) fastened on the top cross-bar and close it with the lock.
5. Rest the cover on the top part in correspondence with the holes and secure it with screws and teflon washers (12-4).
6. Part C: make 4 holes of Ø5 in correspondence to the stamp and secure with screws (4) and washers (12).

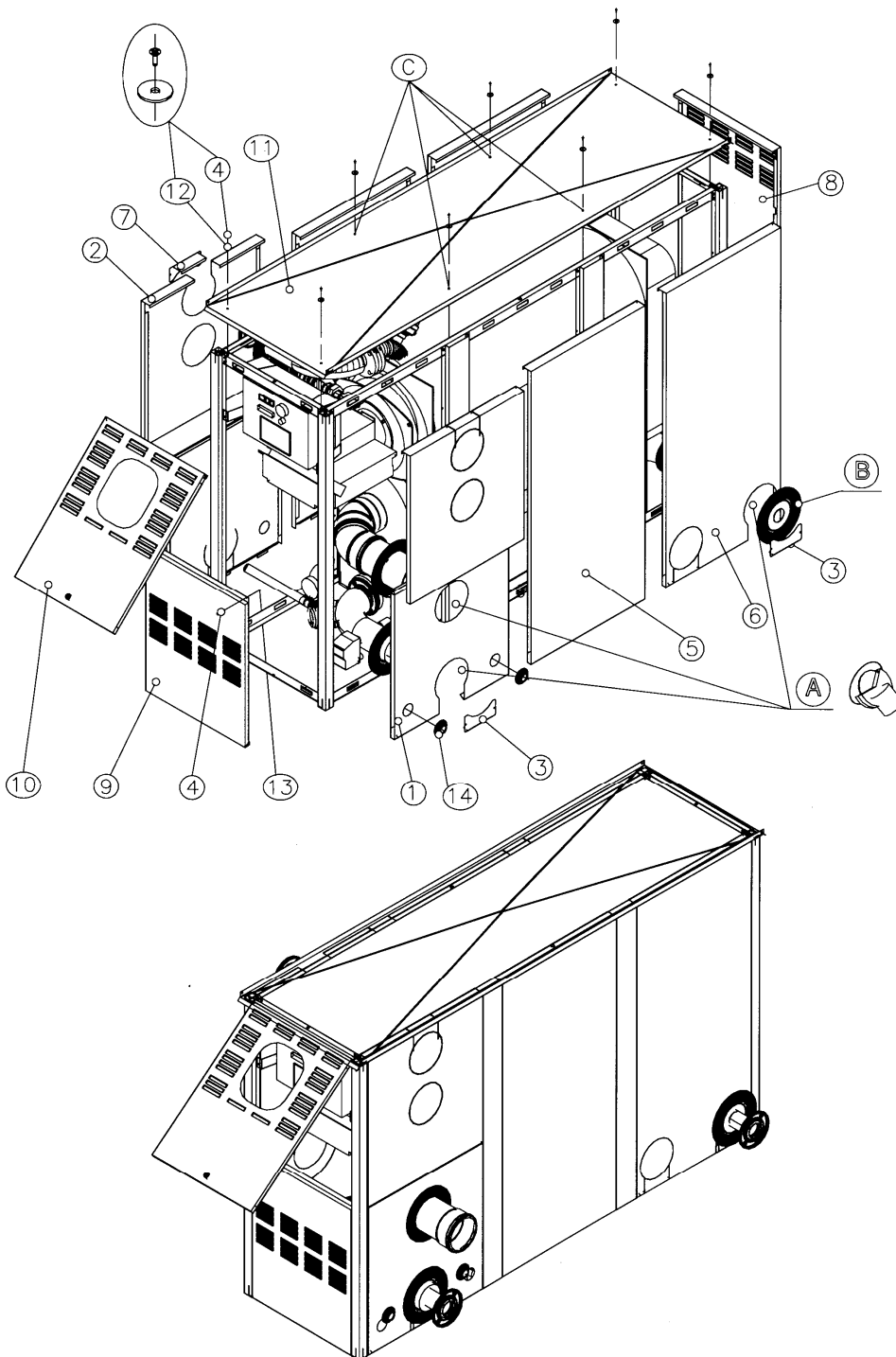

- LEGEND**
1. Front/back dx sx side
 2. Front/top dx sx side
 3. Pipe for buttonhole
 4. Screws 4x8m
 5. Center dx sx side
 6. Back dx sx side
 7. Pipe for buttonhole
 8. Back panel
 9. Lower door
 10. Opening door
 11. Cover
 12. Teflon washer
 13. 4m inox nut
 14. Fairlead

Fig. 6

5.6 MODULAR UNIT PIPING INSTALLATION KIT (Fig. 8)

1. Set the output side (dx or sx) of the collectors and close the other side with flanges and bottoms. Mount the shut-off valve module (V) as shown in the diagram.
2. Mount the following collectors with the relative gaskets and secure them with the provided screws::
 - System release DN 100 (1)
 - Low-temperature return system DN 100 (2)
 - Medium-temperature return system DN 100 (3)

NOTE: IF ONLY ONE RETURN IS REQUIRED, ALWAYS USE THE LOW TEMPERATURE ONE (2)

- Gas input DN 50 att. 3/4" (4)
 - Condensation release (5)
3. Secure the flue support pipes (S) to the collector (2) as shown in the diagram. The pipes are adjustable with the nuts to obtain the correct positioning of the flue.
 4. Mount the Ø 250 flue collector (6)
 5. Install the medium-temperature return system collector (2) with the safety accessories: safety valve (7), the maximum pressure regulator (8), the water flow switch (9) and the gauge (10).
 6. Insert the rubber holding washers (11) in the release/return collectors (cut them according to the pre-cut) and gas.
 7. Verify that the boiler is perfectly level, noting the bars (12) and plates (13) to guarantee a proper condensation drainage.

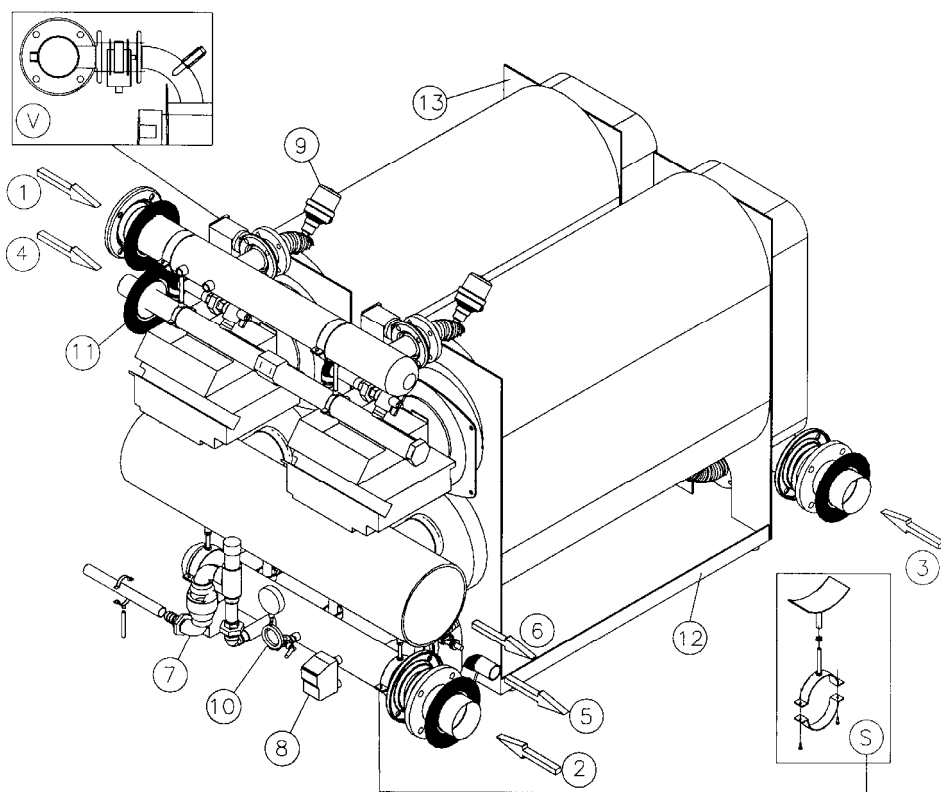

LEGEND

1. System release DN 100
2. Low-temperature return system DN 100
3. Medium-temperature return system DN 100
4. Gas input DN 50 att. 3/4"
5. Condensation release
6. Flue collector Ø 250
7. Safety valve 1/2"
8. Maximum and minimum pressure regulator 1/4"
9. Water flow switch 1"
10. Gauge 3/8"
11. Holding washers
12. Bars
13. Boiler plates
14. Boiler release 3/4"
- V Shut-off valve module
- S Supporting flue pipes

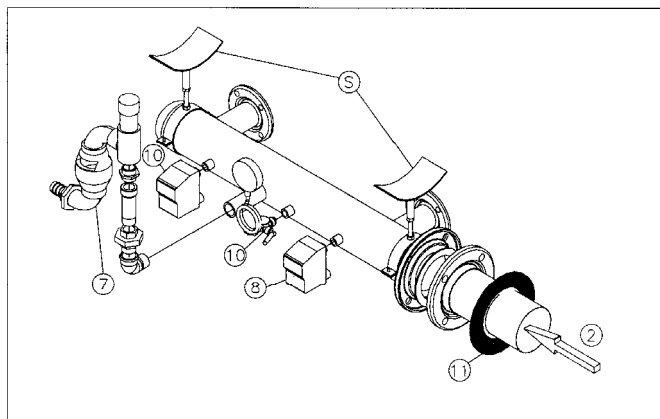
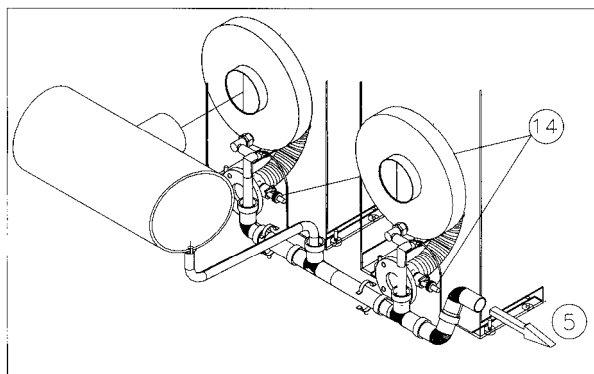
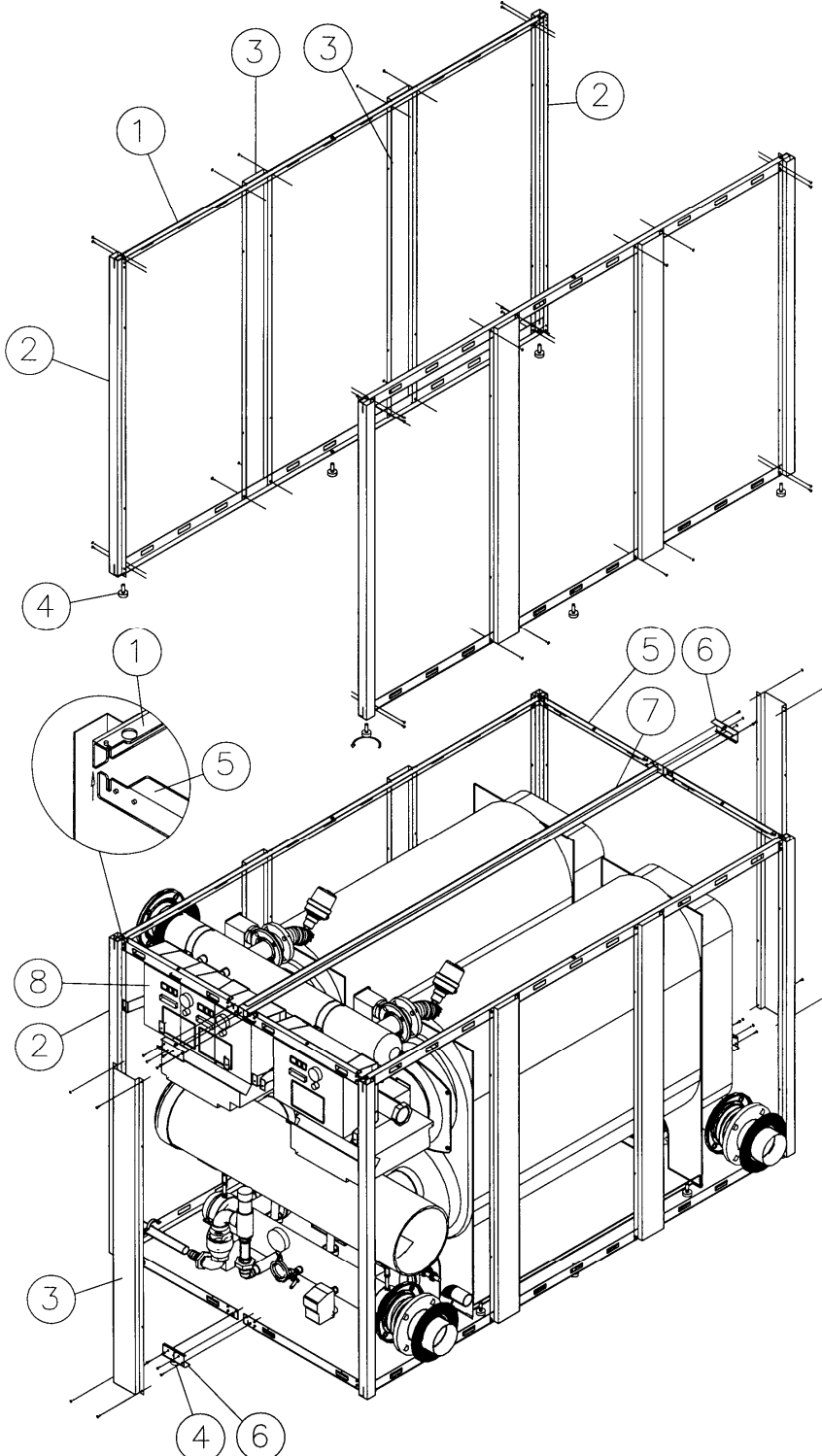

Fig. 8

6 MODULAR UNIT COVER ASSEMBLY

6.1 MODULAR UNIT FRAME COVER (Fig. 9)

1. Assemble the dx and sx sides securing the bars (1) with the mounts (2 and 3) utilising the provided M4 screws.
2. Screw the adjustable feet (4) on the lower bars.
3. Rest the sides of the boiler.
4. Fasten the cross-bars (5) to the bars (1) as illustrated in the diagram. Secure them with the provided screws and connect them with the pipe (6).
5. Secure the cross-bars (5) with the cover bar (7) and mounts (3) using the appropriate screws.
6. Mount the control panel (8) to the front cross-bar (5) and secure it to the mounts with the appropriate screws.
7. Insert the bulbs in the provided holes in the shell (thermostat adjustment 1st and 2nd flame, safety thermostat, boiler thermometer, electric switchboard probe).



LEGEND

1. Bars
2. Front/back mounts
3. Side mounts
4. Adjustable feet
5. Cross-bars
6. Connecting pipe
7. Cover bar
8. Control panel

Fig. 9

6.2 MODULAR UNIT COVER PANELS (Fig. 10)

1. Remove the pre-cut pieces only in correspondence to the piping as illustrated (par. A).
2. Fasten the sides (1) and secure them with screws and nuts (4-14), fasten the sides (2-5-6) adapting the gaskets (part. B), secure the pipes for the buttonhole (3-7) with attached 2-sided adhesive.
3. Cut the fairlead (15) for safety valve pipe output and condensation release (part. B). There are holes to secure the frame to the ground on the front/back cross-bars on the bottom of the frame.
4. Fasten the bottom door (9) to the the back panel (8) and secure it with screws (4) and nuts (14) and fasten it to the mounts. Fasten the opening door (10)
5. on the top cross-bar and close it with a lock. Lean the cover (11) on the top part in correspondence with the holes and secure it with screws and teflon washers (4-13). Insert the roof closure profile (12) and secure it with screws and nuts (4-14).
6. Part. C: make 4 holes of $\varnothing 5$ in correspondence to the stamps only on the two extremities (dx-sx) and secure with screws (4) and washers (13).

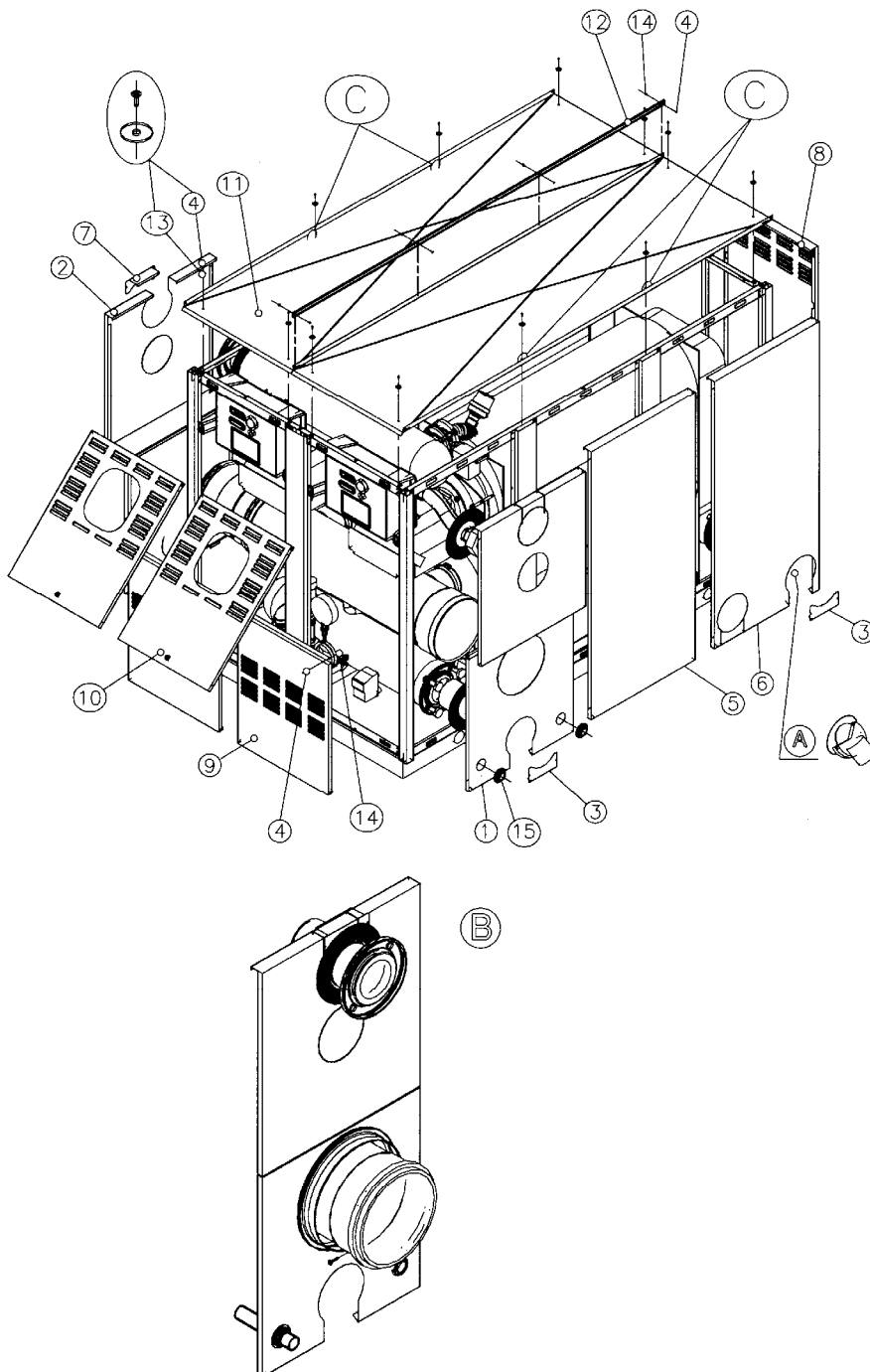

LEGEND

1. Front bottom dx sx side
2. Front top dx sx side
3. Pipe for return buttonhole
4. Screws 4x8m
5. Central dx sx side
6. Back dx sx side
7. Pipe for mand. buttonhole
8. Back panel
9. Lower door
10. Opening door
11. Cover
12. Roof closure profile
13. Teflon washers
14. m4 inox nut
15. Fairlead

Fig. 10

7 START UP

7.1 PRELIMINARY CHECKS

Before starting the boiler, check that:

- The **rating plate** specifications and power supply network (electricity, water, gas) specifications correspond;
- The burner **power range** is compatible with the power of the boiler;
- The boiler room also contains the instructions for the burner;
- The **flue gas exhaust pipe** is operating correctly;
- The **air inlet supply** is well dimensioned and free from any obstacle;
- The **boiler door**, the **smoke box** and the **burner plate** are closed in order to provide a complete flue gas seal;
- The system is **full of water** and that any **air pockets** have therefore been eliminated;
- The **anti-freeze** protections are operative;
- The water **circulation pumps** are operating correctly.
- The expansion vessel and the safety valve(s) have been connected correctly (with no interception) and are properly operating.
- Check the electrical parts and thermostat operation.

7.2 WATER TREATMENT

If the boiler is to be installed in an existing system where there could be frequent losses from the system or if the hardness of the water is greater than 10 F, it will be necessary to use a filter and a softener for system water and control the pH above 8-9.

The most common phenomena that occur in heating systems are:

- Scaling

Scale obstructs heat transfer between the combustion gases and the water, causing an abnormal increase in the temperature of the metal and therefore reducing the life of the boiler.

Scale is found mostly at the points where the wall temperature is highest and the best remedy, at construction level, is to eliminate areas that overheat.

Scale creates an insulating layer, which reduces the thermal transfer of the boiler, affecting system efficiency. This means that the heat produced by burning the fuel is not fully transferred and is lost to the flue.

Scale diagram

Key

% % fuel not used
mm mm scale

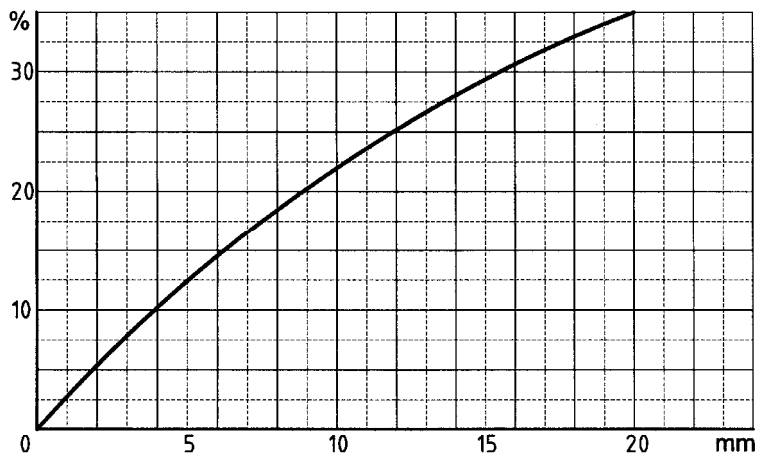

- Corrosion on the water side

Corrosion of the metal surfaces of the boiler on the water-side is due to the passage of dissolved iron through its ions (Fe⁺). In this process the presence of dissolved gases and in particular of oxygen and carbon dioxide is very important. Corrosion often occurs with softened or de-mineralised water, which has a more aggressive effect on iron (acid water with Ph <7): in these cases, although the system is protected from scaling, it is not protected against corrosion and the water must be treated with corrosion inhibitors.

7.3 FILLING THE SYSTEM

The water must enter the system as slowly as possible and in a quantity proportional to the air bleeding capacity of the components involved.

In the case of a system with **closed expansion vessel**, water must be let in until the pressure gauge indicator reaches the static pressure value, pre-set by the vessel. Heat the water to maximum temperature and never over 90°C. During this operation, the air contained in the water is released through the automatic air separators or through manual bleed valves. The water released from the system with elimination of the air is made up by the automatic or manual-filling valve.

8 OPERATION

8.1 IGNITION (Fig. 11)

1. Open the gas tap (check if there is any gas leakage).
2. Power the control panel with the master switch (1)
3. Power the burner with the switch (2).
4. Verify that the safety thermostat is equipped (8).
5. Verify that the water circulation is sufficient (if the circulation is insufficient, the water flow switch intervenes, stopping the ignition of the burner). The necessary water supply must guarantee a thermal gradient between release and return of 15°C.

It is possible to select the AUT/MAN operation mode (5): the burner is activated upon the correct calibration of the thermostat knob (MAN function) or the setting the thermoregulator switchboard values (AUT function).

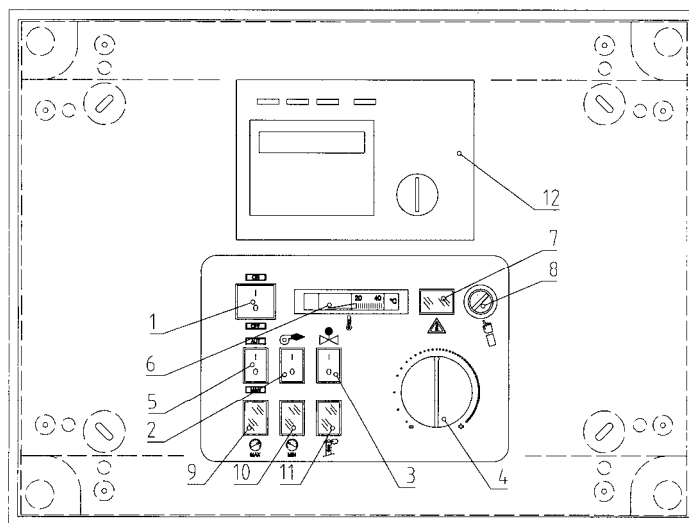

Fig. 11

LEGEND

- 1 MASTER SWITCH/NETWORK INDICATOR
- 2 BURNER SWITCH
- 3 MOTORIZED RELEASE VALVE INDICATOR
(With selector 5 in AUT) 1=active valve 0=valve always closed
(With selector 5 in MAN) 1=valve always open 0=valve always closed
- 4 BITHERMOSTAT REGULATOR 1a-2a FLAME
- 5 MAN/AUT SELECTOR
- 6 BOILER THERMOMETER
- 7 THERMOSTAT BLOCK SAFETY INDICATOR
- 8 SAFETY THERMOSTAT
- 9 MAX PRESSURE REGULATOR INTERVENTION INDICATOR
- 10 MIN PRESSURE REGULATOR INTERVENTION INDICATOR
- 11 FLUE PRESSURE REGULATOR INTERVENTION INDICATOR
- 12 RVA 63 SWITCHBOARD

NB.

It is common to find air inside the gas pipe-work, especially during the initial start up or after a long period of without use. So if the flame failure occurs, repeat the same operation as previously explained.

CONNECTION LIVE/NEUTRAL

If the connections of the live and the neutral are not correct, the burner will stop at the end of the safety time (even if the burner is running).

9 OPERATION

ATTENTION:

This operation and all regulation, verification, periodic checks and maintenance operations must be performed by professionally-qualified personnel.

9.1 OPERATION CHECKS

The heating system must be used suitably, ensuring on the one hand, optimum combustion with reduced emission to the atmosphere of carbon monoxide, hydrocarbons and soot, and on the other avoiding all damage to persons and property.

The pressurisation must remain within the limit values shown in the technical data table.

In the case of flue gas leaks from the front and rear of the boiler (front/rear door and fume chamber), the closure tie rods of the single parts must be adjusted; if this is not sufficient, replace the gaskets.

WARNING

Do not open the door and do not remove the fume chamber while the burner is in operation. In all cases wait a few minutes after stopping the burner for the insulation to cool.

9.2 TEMPORARY BOILER STOP

To stop the boiler temporarily, set the main switch on the control panel to "OFF". The electrical parts will now be free of power.

9.3 PROLONGED BOILER STOP

Close the gas valve that is fitted upstream of the boiler

WARNING: During long stoppages in winter, and in order to avoid frost damage, freeing the heating system is recommended. The adding of antifreeze liquids in proportion to the installation site is recommended regardless.

9.4 PERIODICAL CHECKS

- Check periodically that there is no air in the heating system
- Periodically check the boiler pressure.

9.5 MAINTENANCE AND CLEANING

All maintenance and cleaning can only be carried out only after closing the fuel supply and switching off the electrical supply.

As economic operation depends on the cleanliness of the heat exchanger surfaces and on burner adjustment, it is recommended to:

- Have the burner settings checked by professionally qualified personnel;
- Analyse the system water and allow for adequate water treatment to avoid the formation of calcareous incrustations that initially reduce boiler efficiency, and then lead to damage;
- Check that the cladding and the flue gas sealing gaskets are in good order and if not, replace;
- Periodically check the efficiency of the regulation and safety instruments on the system.

NOTE

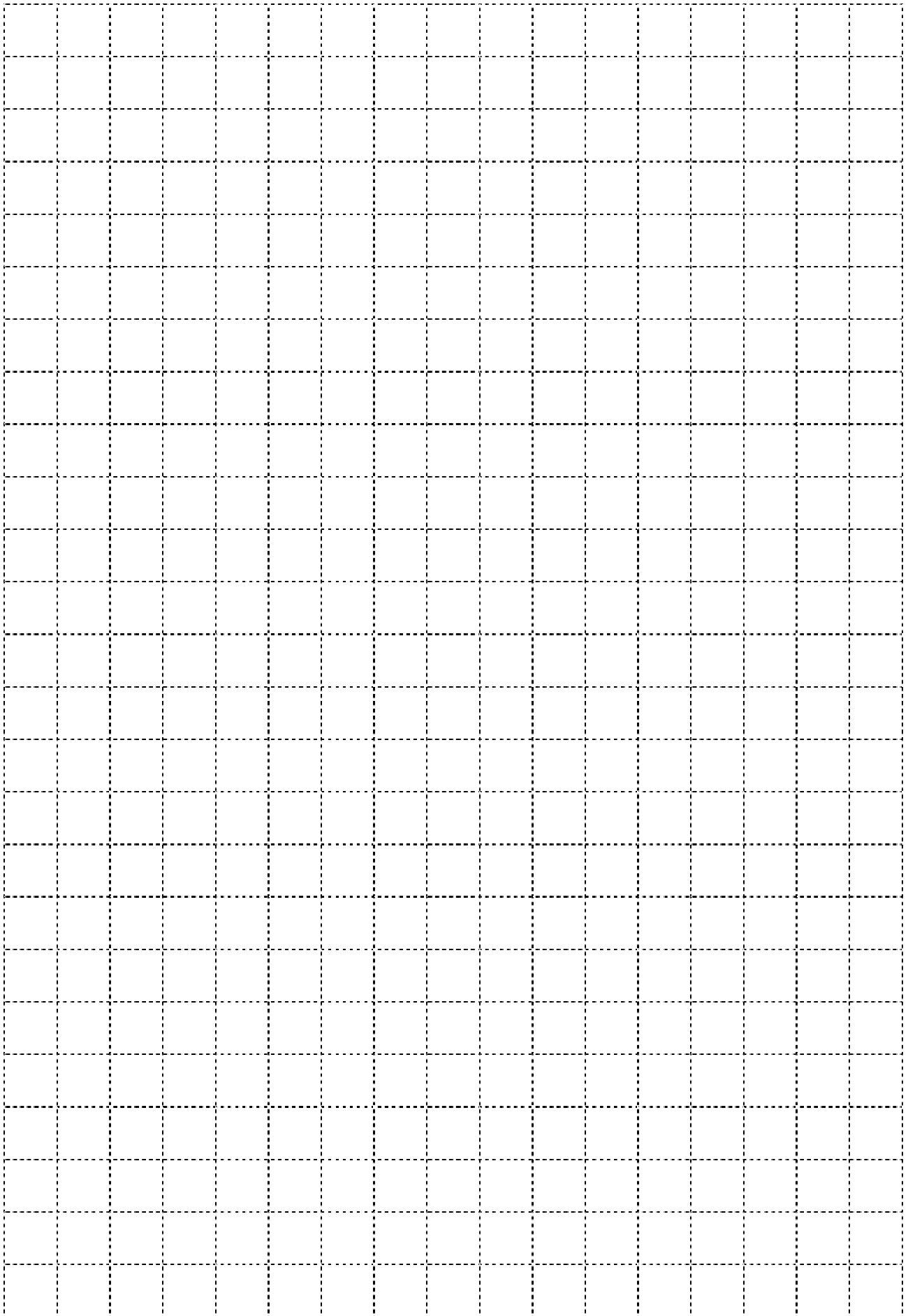



alta tecnologia del calore

ICI CALDAIE SpA
Via G. Pascoli, 38
37059 Campagnola di Zevio VR

Telefono 045 8738511
Fax 045 8731148
Info@icicaldaie.com
www.icicaldaie.com

Partita Iva 00227490232
Rag. Soc. n. 6677
C.C.I.A.A. VR n. 69600

Appartenente al Gruppo Finluc
Iscritto R.I. VR 02245640236

DECLARATION OF CONFORMITY WITH THE EUROPEAN COMMUNITY REGULATIONS

I undersigned Emanuela Lucchini, Managing Director of ICI CALDAIE S.p.A., headquartered in via G. Pascoli 38 – 37059 Campagnola di Zevio (VR) Italy

DECLARE THAT STEEL BOILERS

WALL - WALL M

comply with the CE certificate and with the following regulations (or harmonised regulations):

EN 60335-1, EN 303-1, pr EN 303-3

In accordance with the boards regulations:

- Gas Directive 90/396/CEE
- Low Voltage Directive 73/23/CEE (modified by 93/68)
- Efficiency Directive 92/42/CEE
- EMC Directive 89/336/CEE

S. Maria di Zevio, li 10/04/2007

ICI CALDAIE S.p.A.
Direttore Generale
Emanuela Lucchini

A handwritten signature in black ink, appearing to read 'Emanuela Lucchini', is written over the printed name.



Appartenente al Gruppo Finluc, iscritto R.I. VR n. 02245640236

Via G. Pascoli, 38 - 37059 Zevio - fraz. Campagnola - VERONA - ITALIA

Tel. 045/8738511 - Fax 045/8731148

info@icicaldaie.com - www.icicaldaie.com

The data listed is indicative only and is not binding. Our company reserves the right to introduce alterations at any time as it deems fit and proper for the development of the product.